

AFONICA MPP

Range of booths for motorcycle workbenches

Afonica MPP is the line of soundproof booths designed and built to allow operators in the motorcycle sector to carry out tests and inspections of motorcycles on a roller bench in full compliance with current safety regulations and without disturbing the work environment.

The Afonica MPP soundproof booths are therefore complete with:

- Door with anti-panic opening and viewing window
- Extraction of flue gases
- Soundproof walls and roof
- Internal ventilation

The outdoor version of each model is also available.

On demand:

- Tailor-made creations
- Supply of electrical plant

For info and price:

- Web: www.afonica.it
- E-mail: info@afonica.it
- Phone: (+39) 0445 397 118

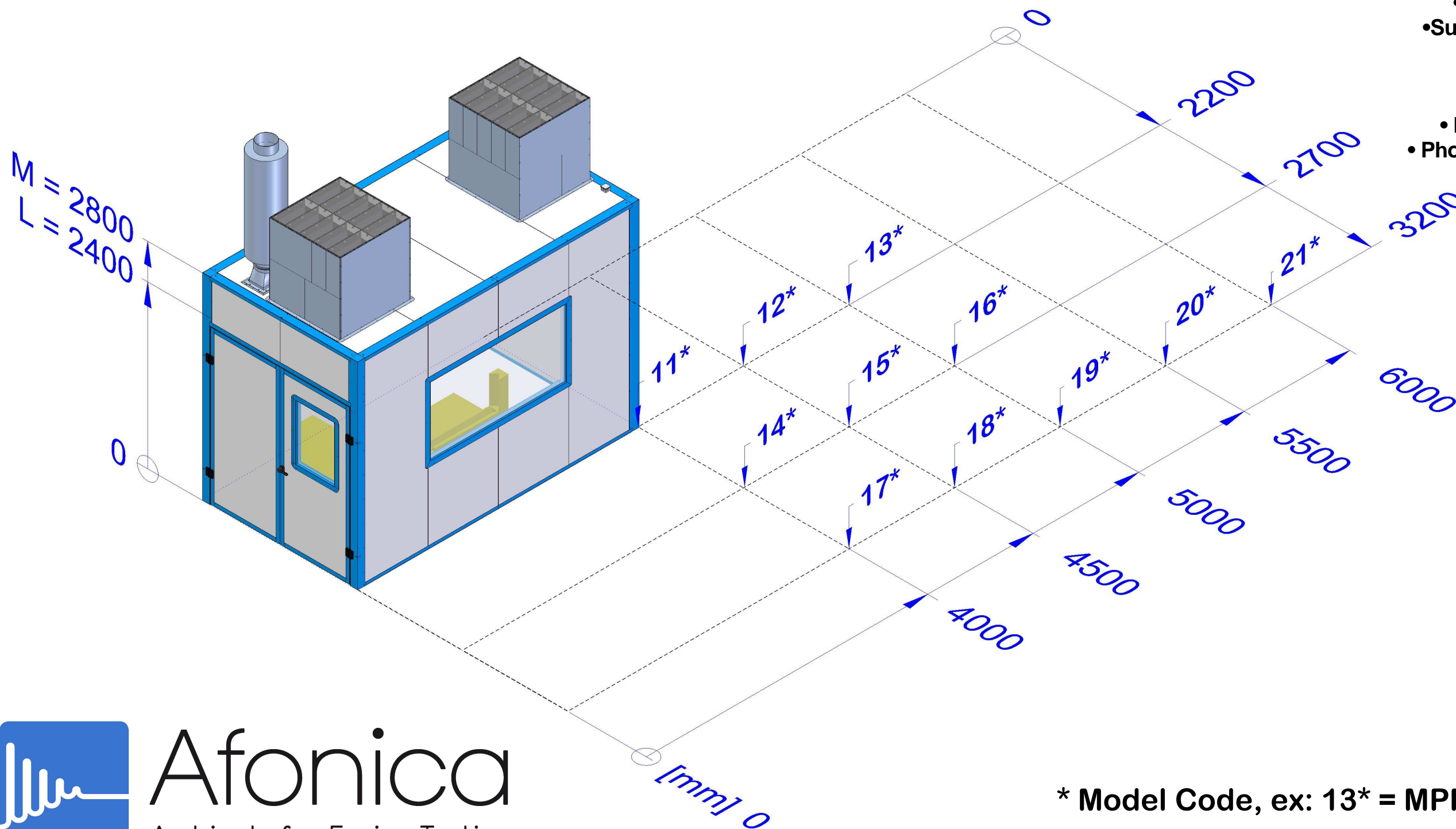

Afonica

Ambients for Engine Testing

* Model Code, ex: 13* = MPP-13

AFONICA MPP RANGE

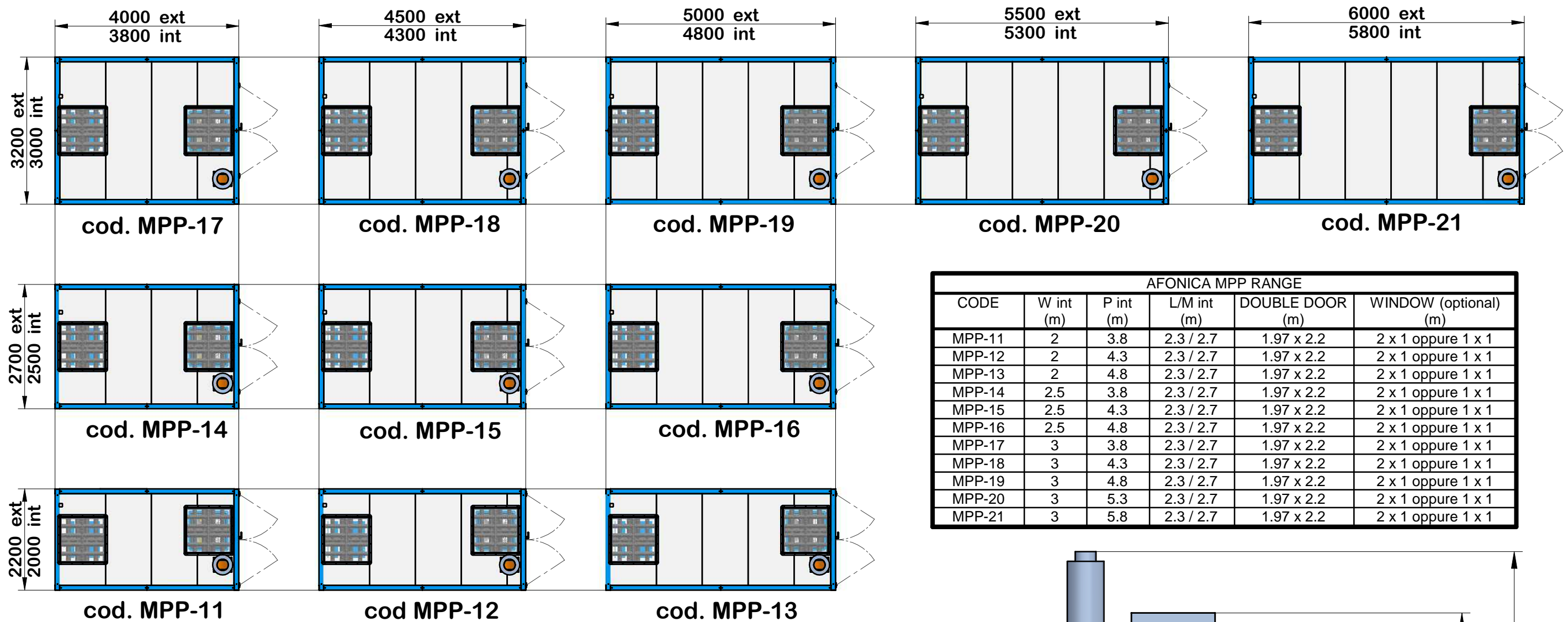

AFONICA MPP RANGE					
CODE	W int (m)	P int (m)	L/M int (m)	DOUBLE DOOR (m)	WINDOW (optional) (m)
MPP-11	2	3.8	2.3 / 2.7	1.97 x 2.2	2 x 1 oppure 1 x 1
MPP-12	2	4.3	2.3 / 2.7	1.97 x 2.2	2 x 1 oppure 1 x 1
MPP-13	2	4.8	2.3 / 2.7	1.97 x 2.2	2 x 1 oppure 1 x 1
MPP-14	2.5	3.8	2.3 / 2.7	1.97 x 2.2	2 x 1 oppure 1 x 1
MPP-15	2.5	4.3	2.3 / 2.7	1.97 x 2.2	2 x 1 oppure 1 x 1
MPP-16	2.5	4.8	2.3 / 2.7	1.97 x 2.2	2 x 1 oppure 1 x 1
MPP-17	3	3.8	2.3 / 2.7	1.97 x 2.2	2 x 1 oppure 1 x 1
MPP-18	3	4.3	2.3 / 2.7	1.97 x 2.2	2 x 1 oppure 1 x 1
MPP-19	3	4.8	2.3 / 2.7	1.97 x 2.2	2 x 1 oppure 1 x 1
MPP-20	3	5.3	2.3 / 2.7	1.97 x 2.2	2 x 1 oppure 1 x 1
MPP-21	3	5.8	2.3 / 2.7	1.97 x 2.2	2 x 1 oppure 1 x 1

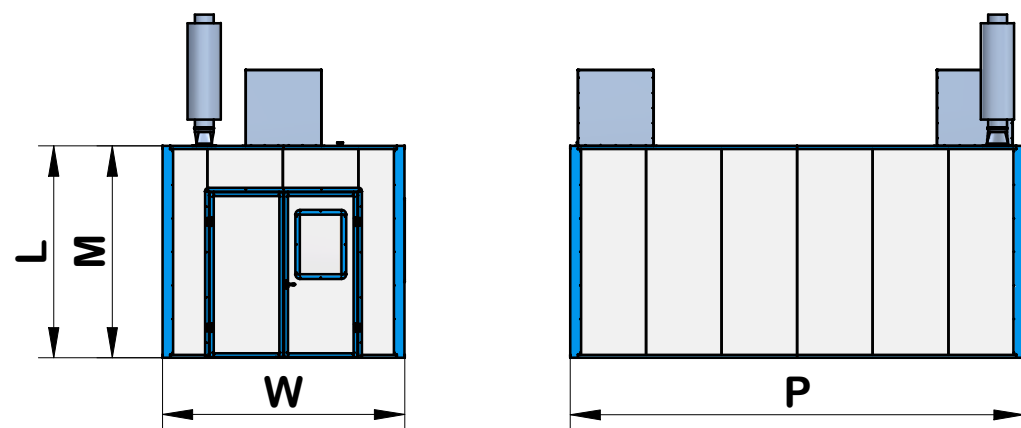

Legenda:
 [W] = Width
 [P] = Depth
 [L] = Minimum Height (ext 2.4 m)
 [M] = Medium Height (ext 2.8 m)

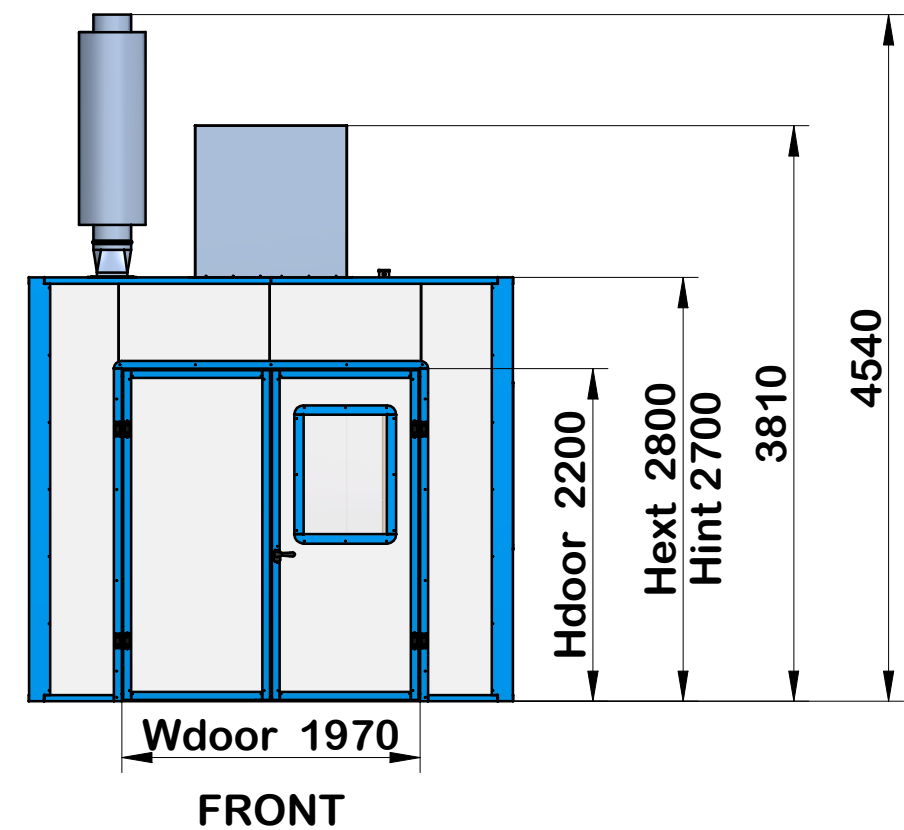

Example Model: MPP-19

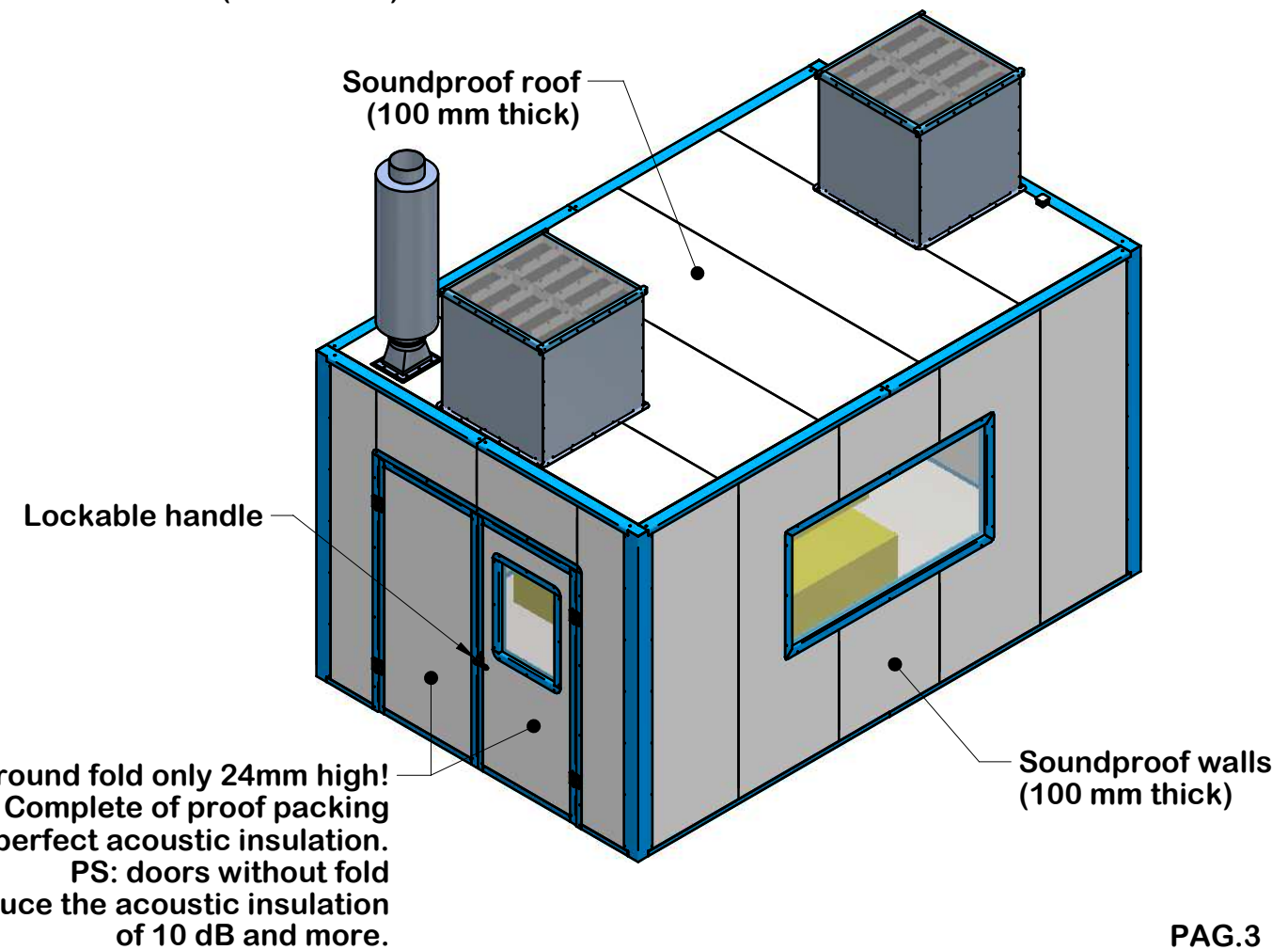
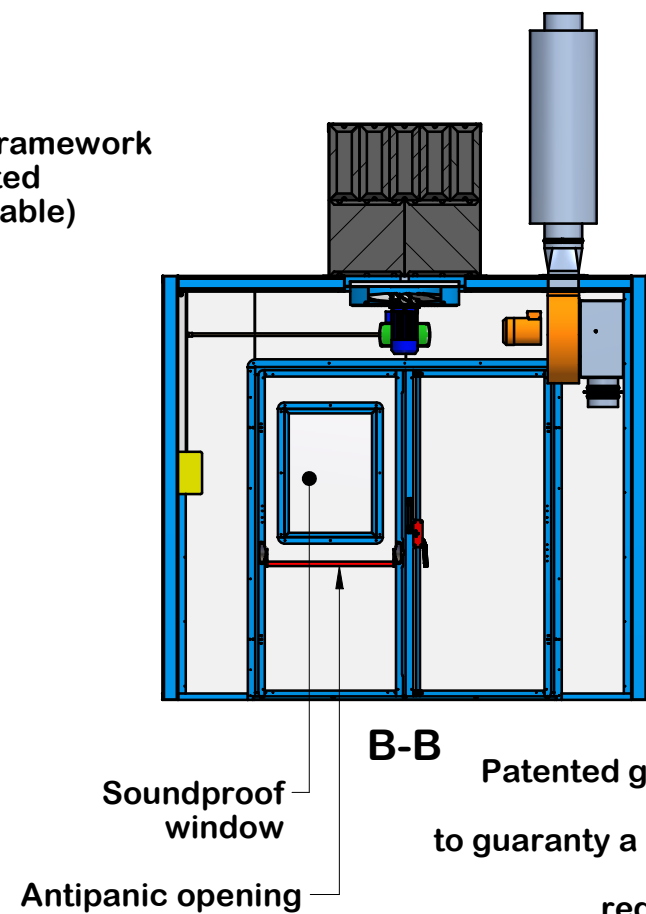
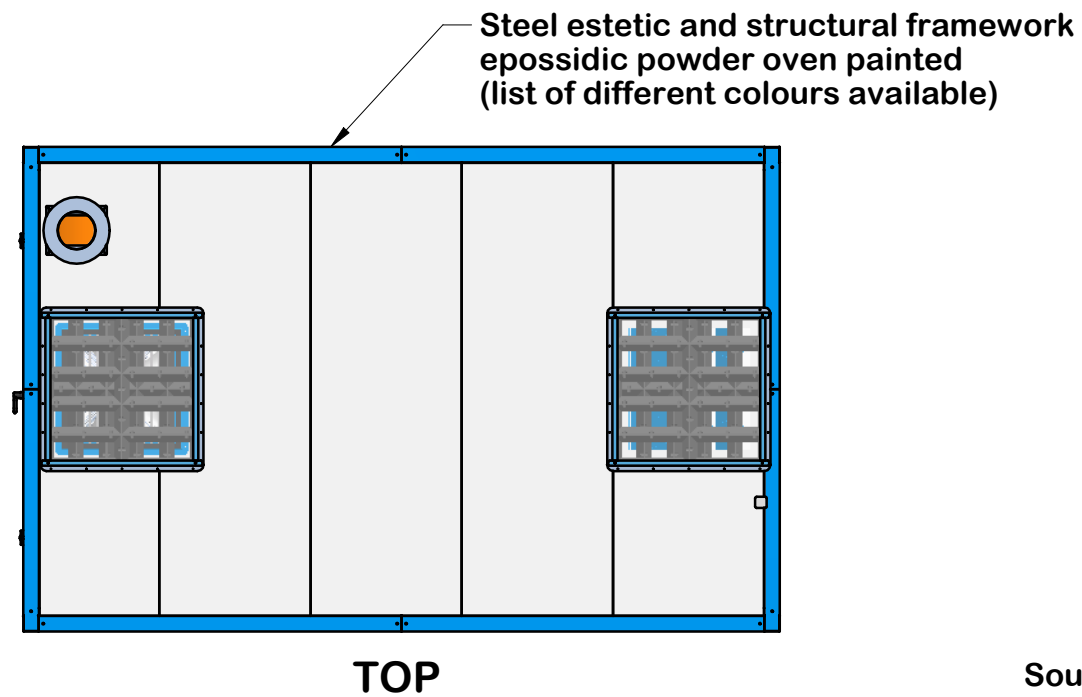
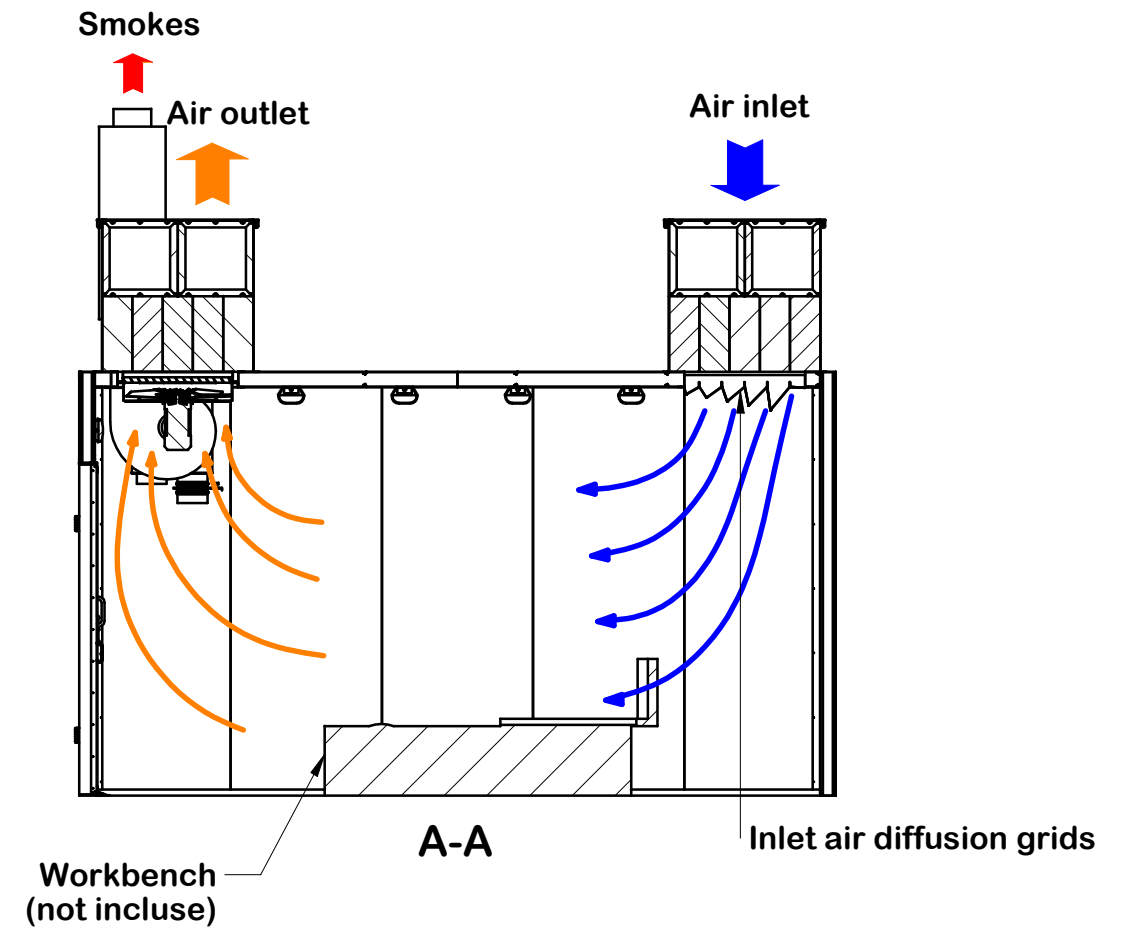
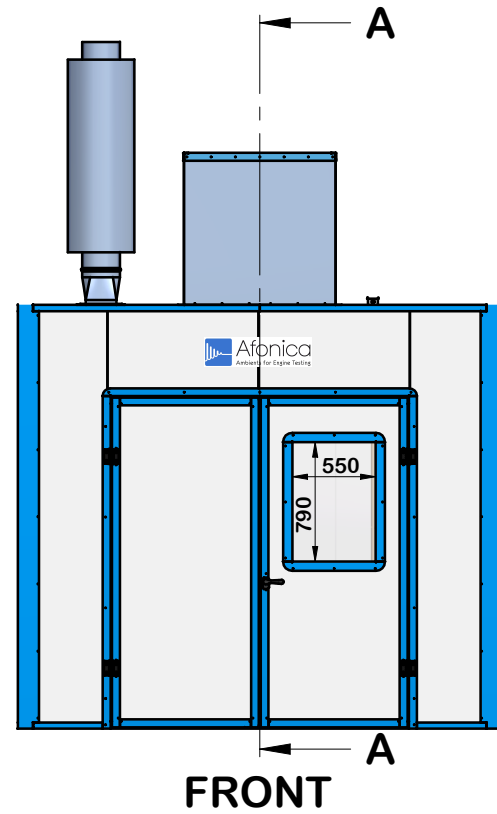
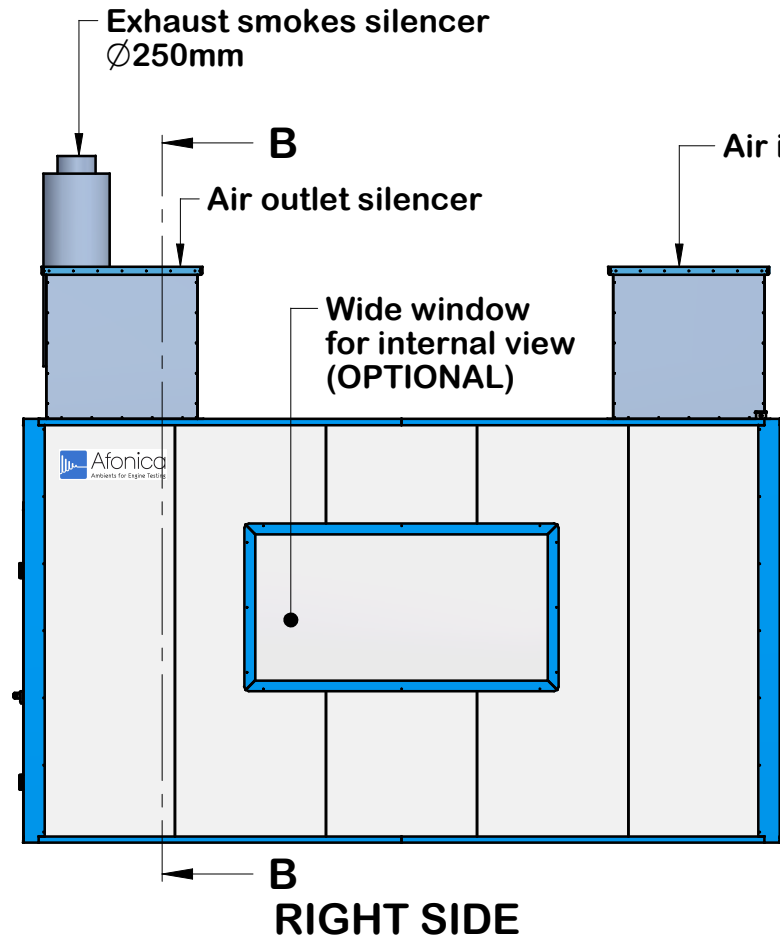

Accessories: Models of SILENCERS

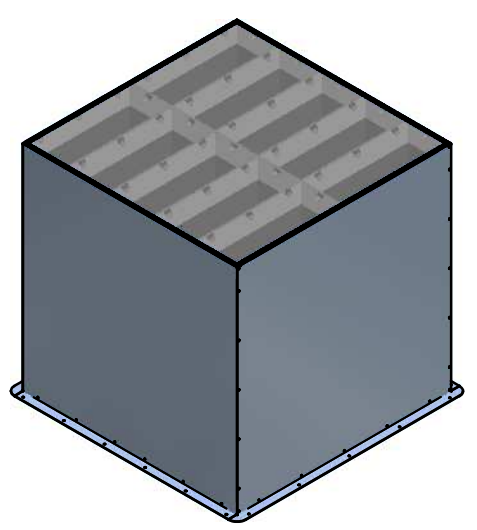
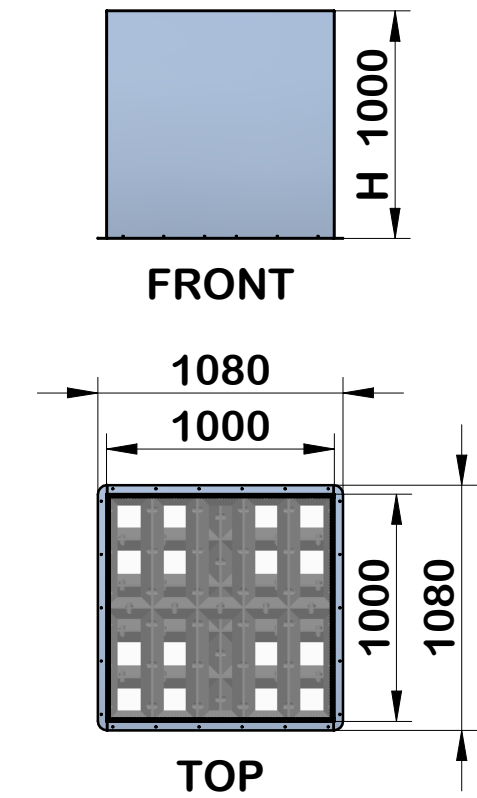

**VERTICAL
SILENCER**

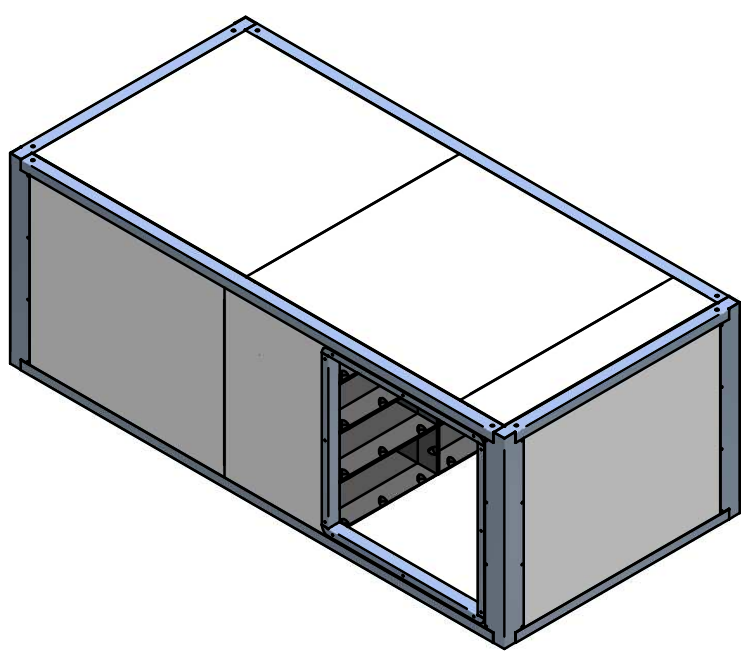
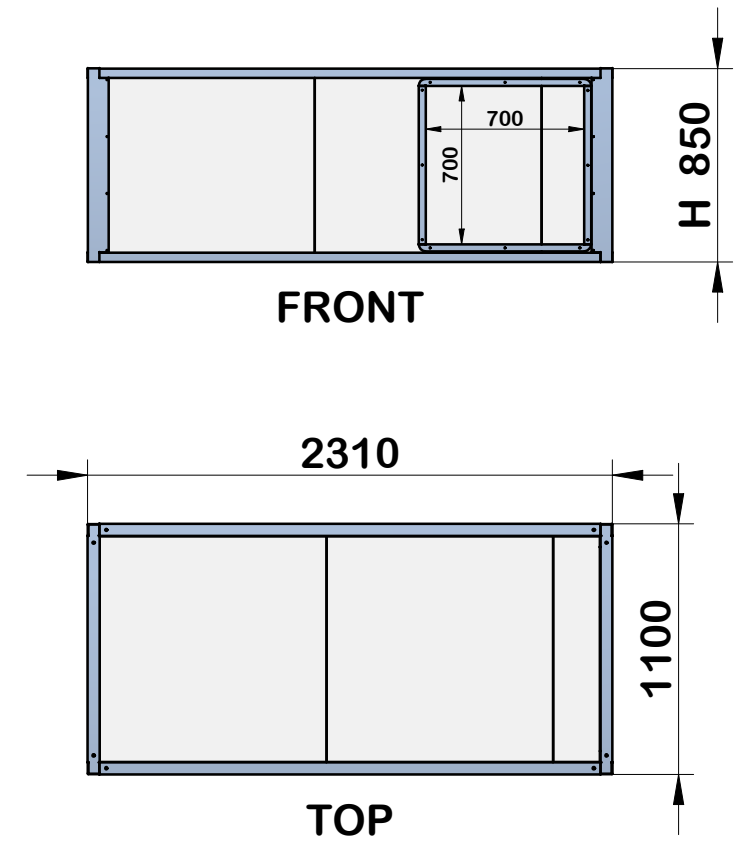

**SIDE
ORIZONTAL
SILENCER**

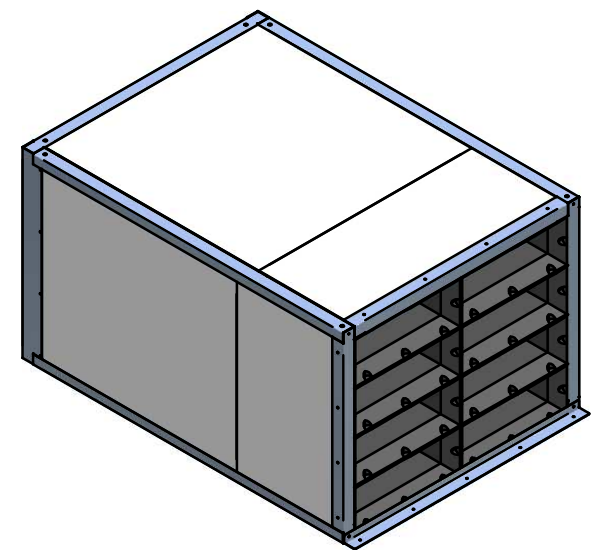
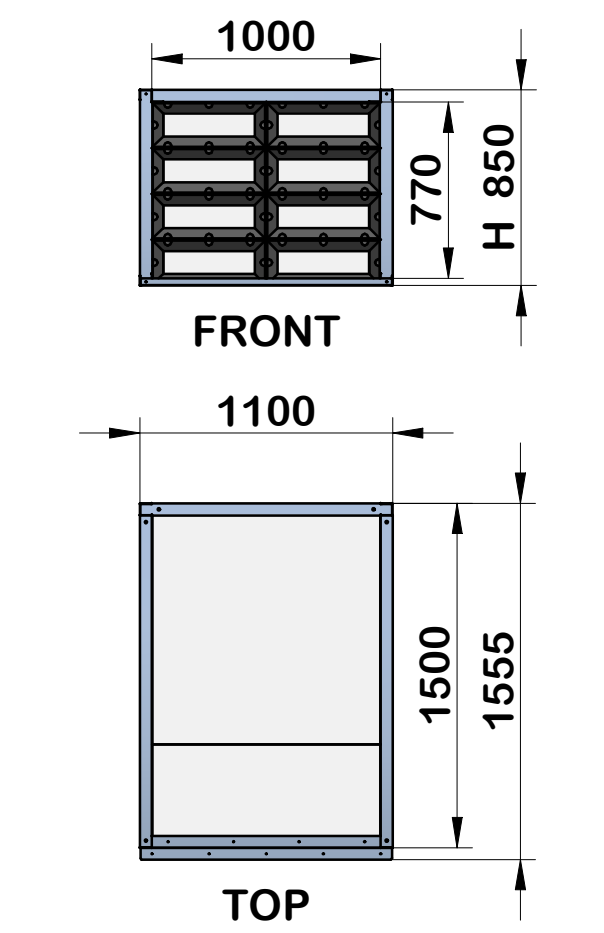

**FRONT
ORIZONTAL
SILENCER**

Accessories: WINDOWS (optional)

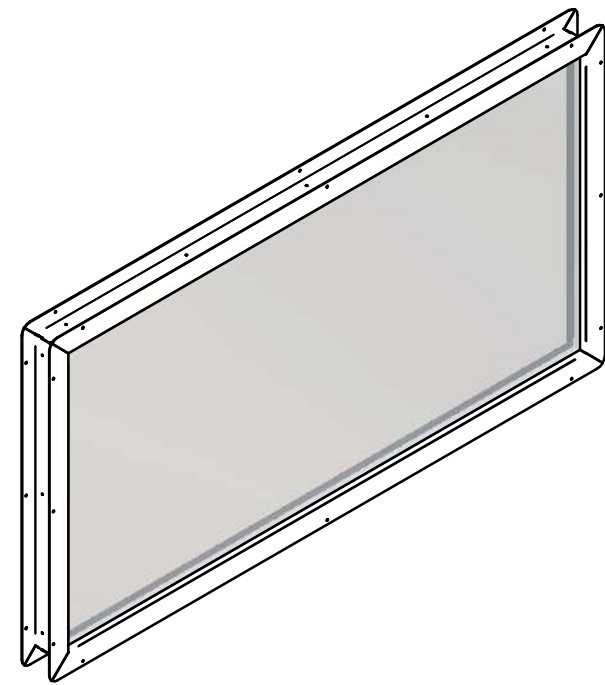
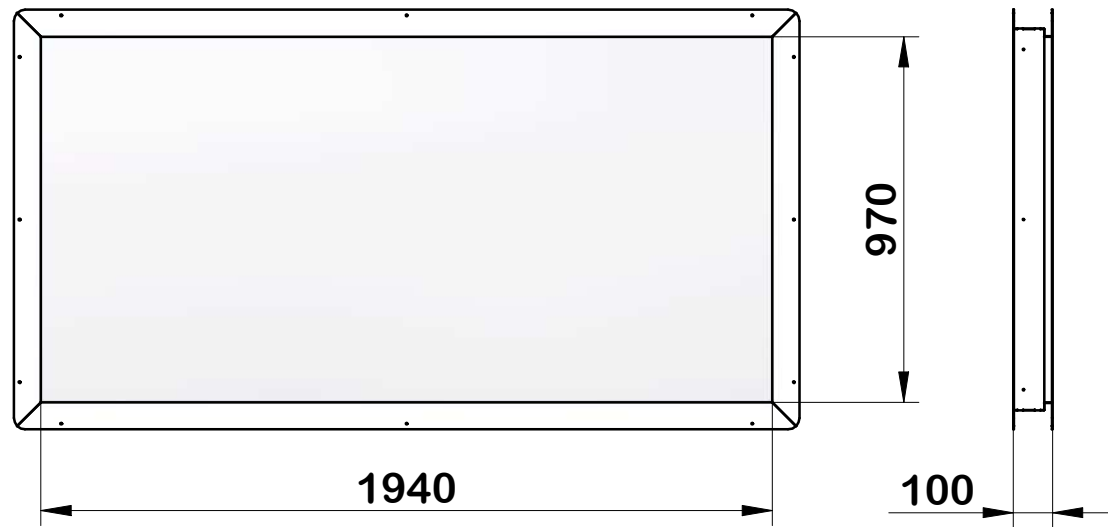

WINDOW
2m x 1m

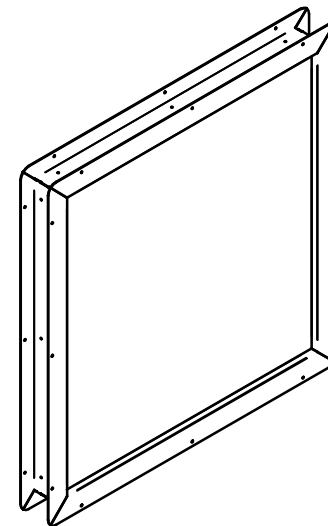
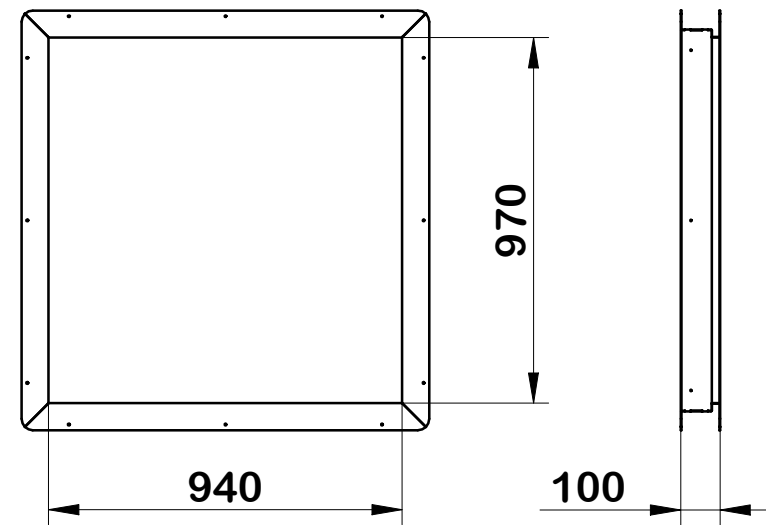

WINDOW
1m x 1m

Accessories*: ELECTRICAL PLANT (optional)

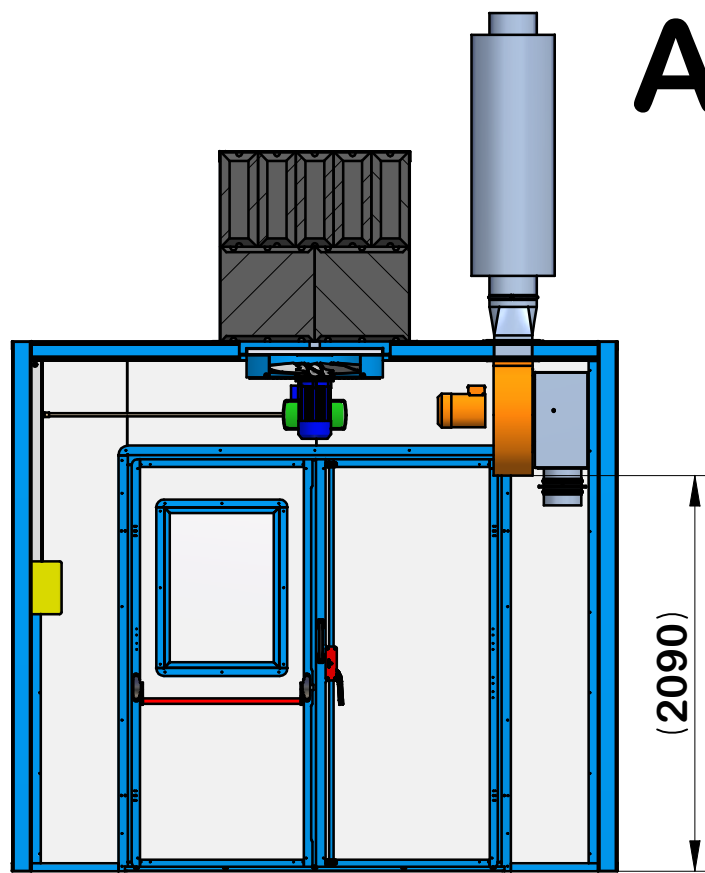

A-A

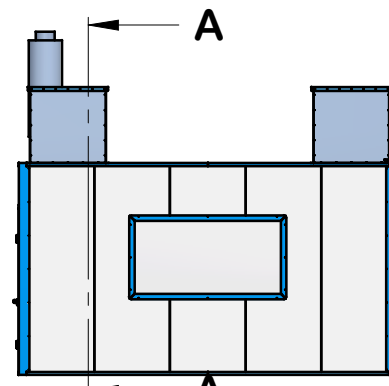
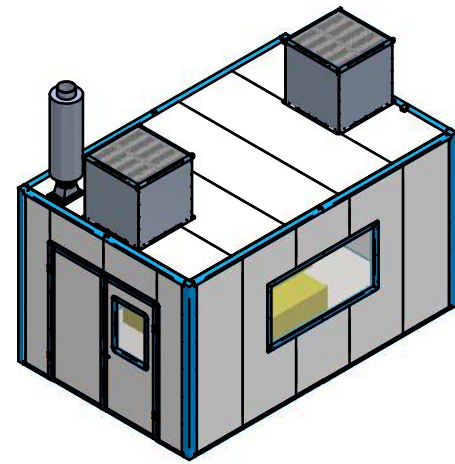

RIGHT SIDE

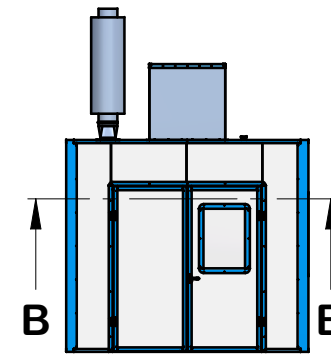

FRONT

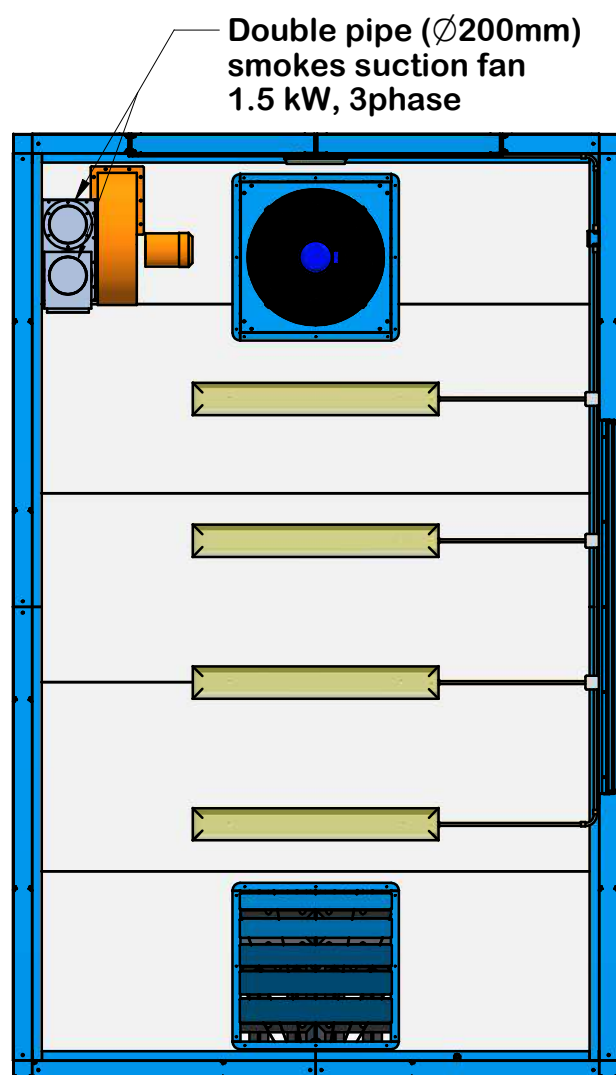

B-B

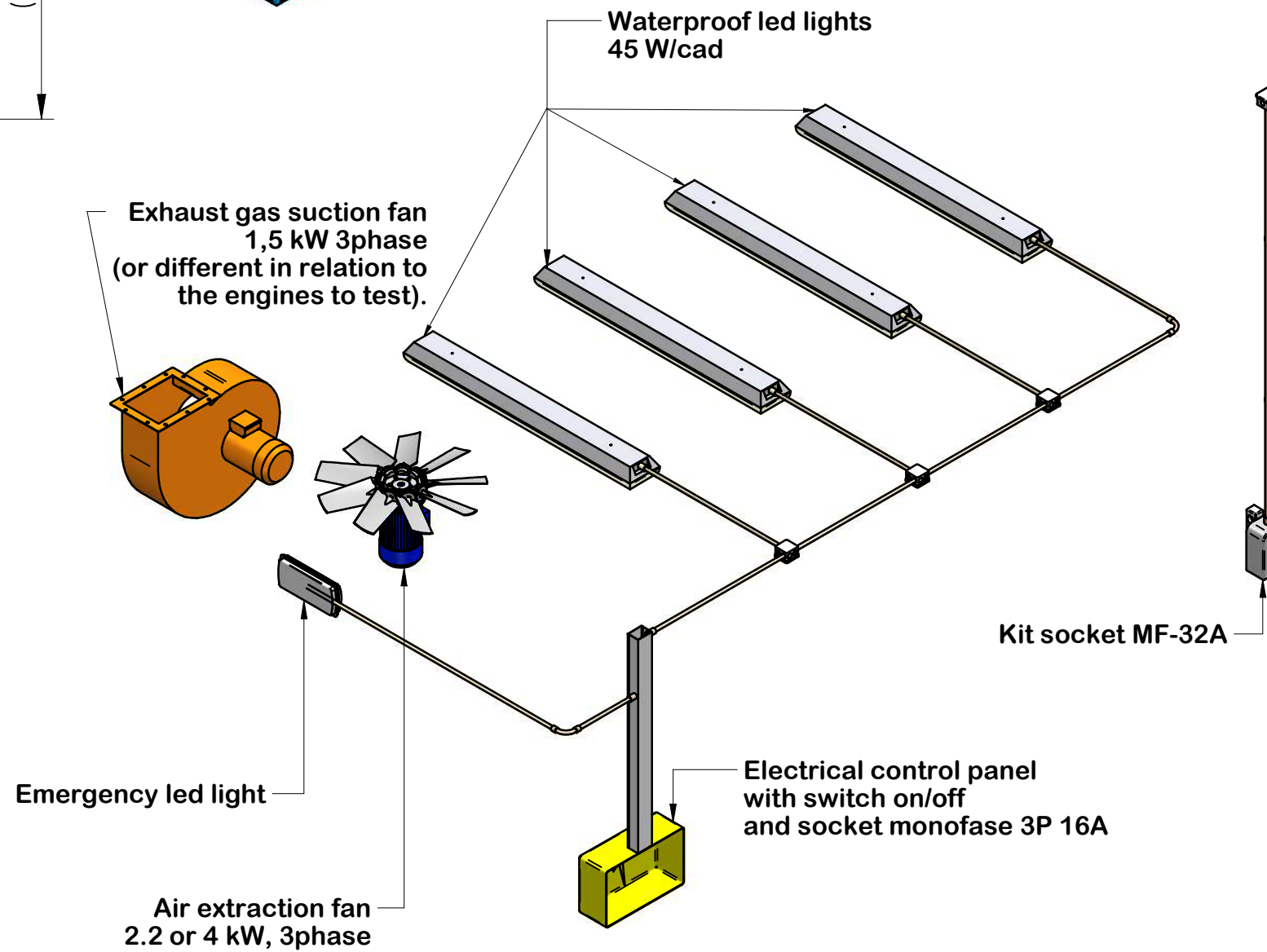

*Available in version 4.0