

AFONICA AST

Range of booths for car workbench

Afonica AST is the line of soundproof booths designed and built to allow operators in the automotive sector to carry out tests and inspections of cars on a roller bench in full compliance with current safety regulations and without disturbing the work environment.

The Afonica AST soundproof booths are therefore complete with:

- Single door with anti-panic opening and viewing window
- Double door with anti-panic opening
- Soundproof walls and roof
- Extraction of flue gases
- Internal ventilation

The outdoor version of each model is also available.

On demand:

- Tailor-made creations
- Supply of electrical plant

Info and price:

- Web: www.afonica.it
- E-mail: info@afonica.it
- Phone: (+39) 0445 397 118

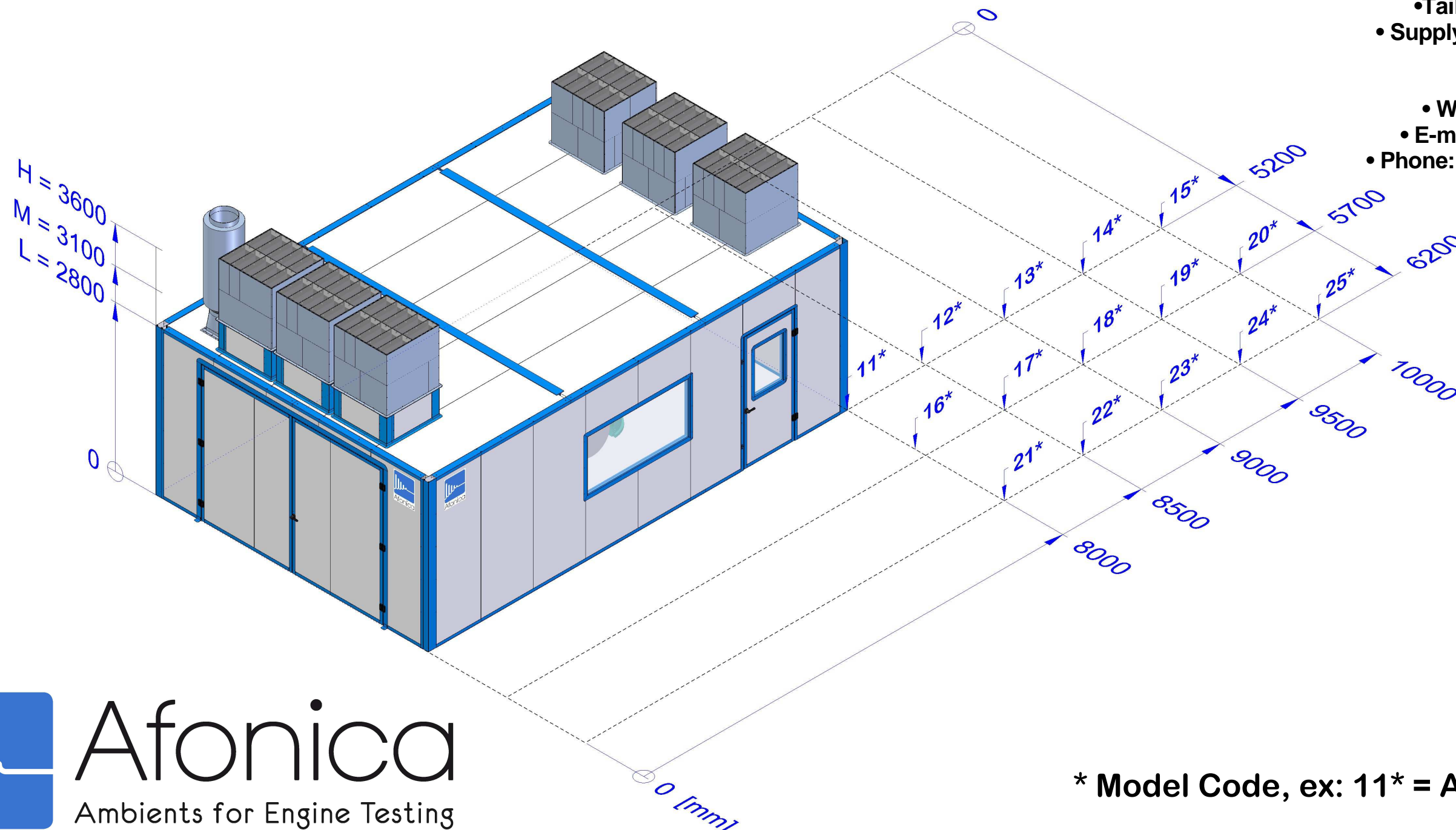

AFONICA AST RANGE

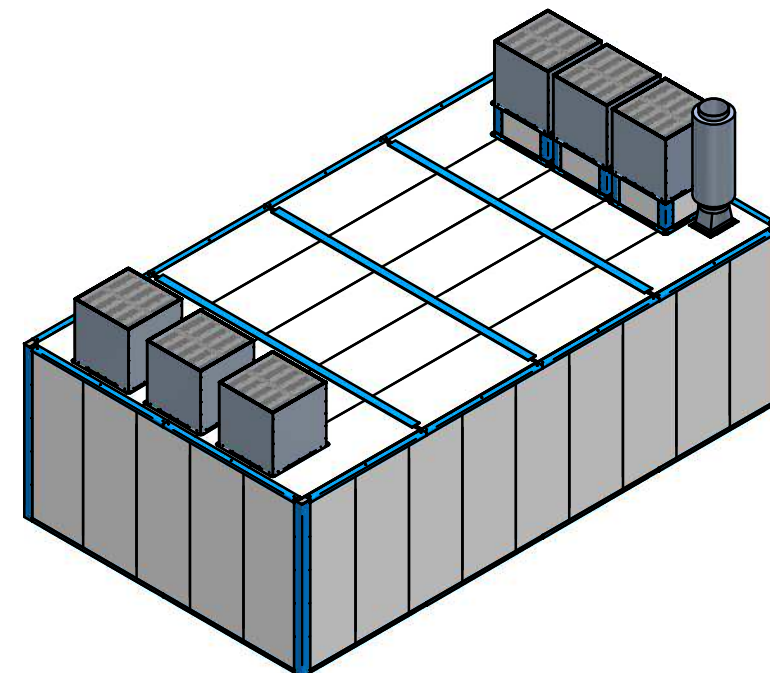
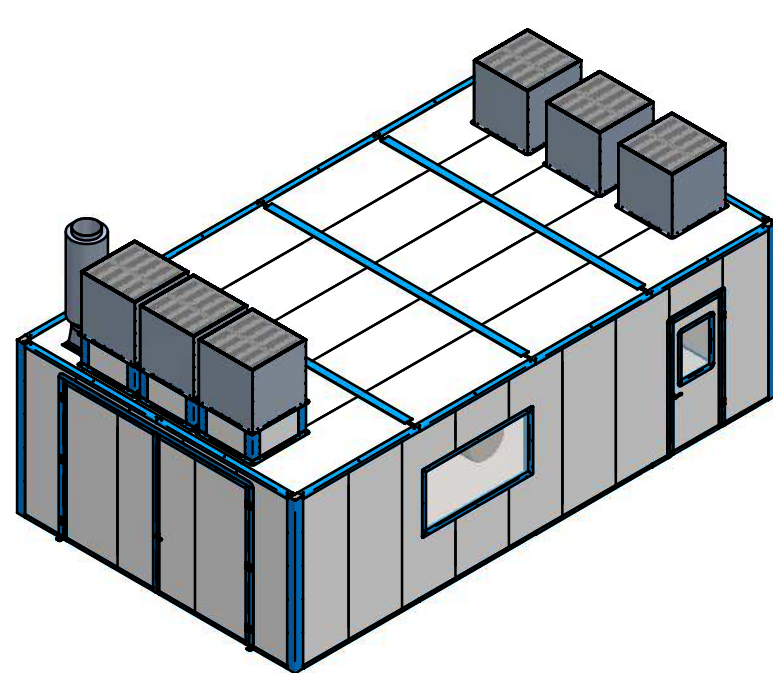
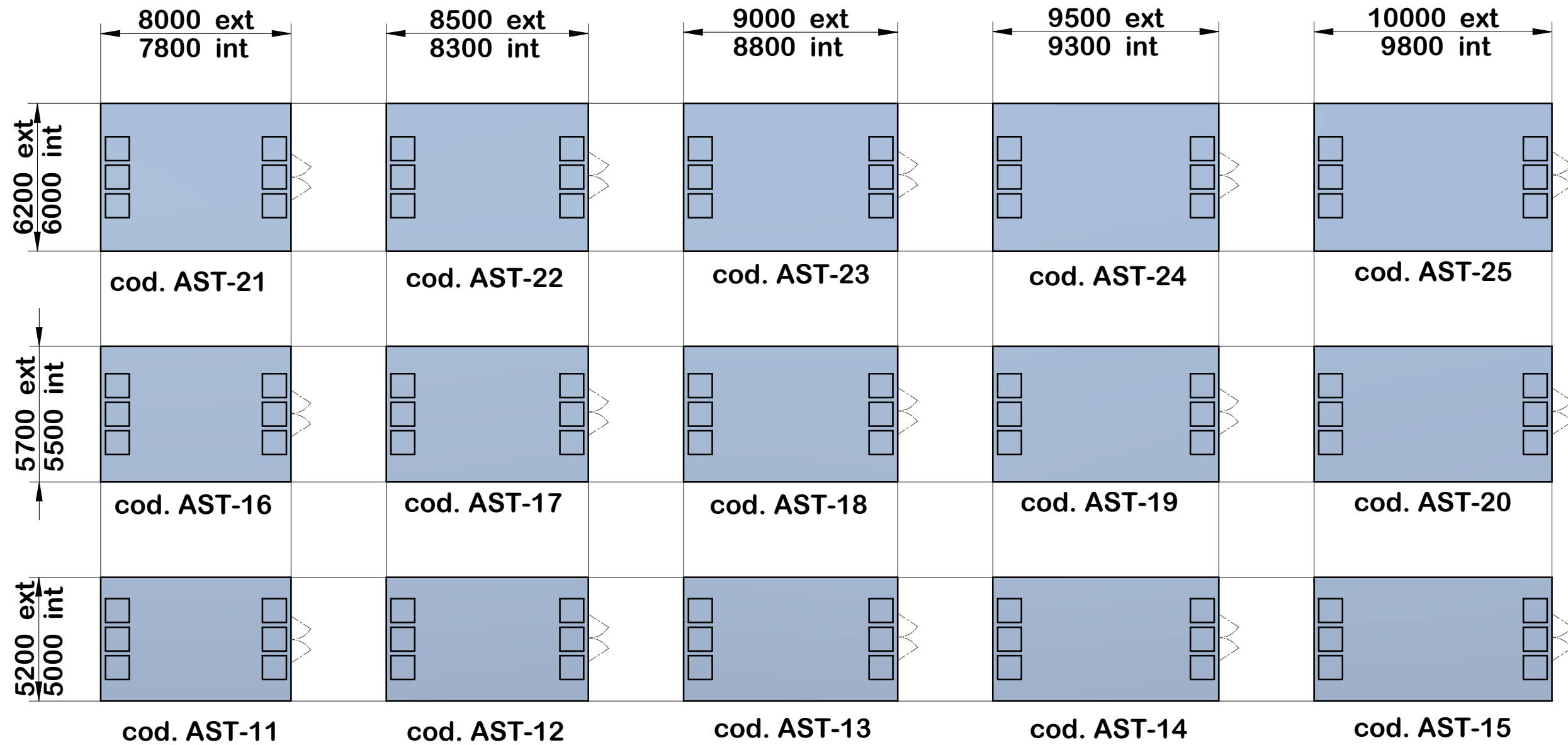

AFONICA AST RANGE

AST-13-L

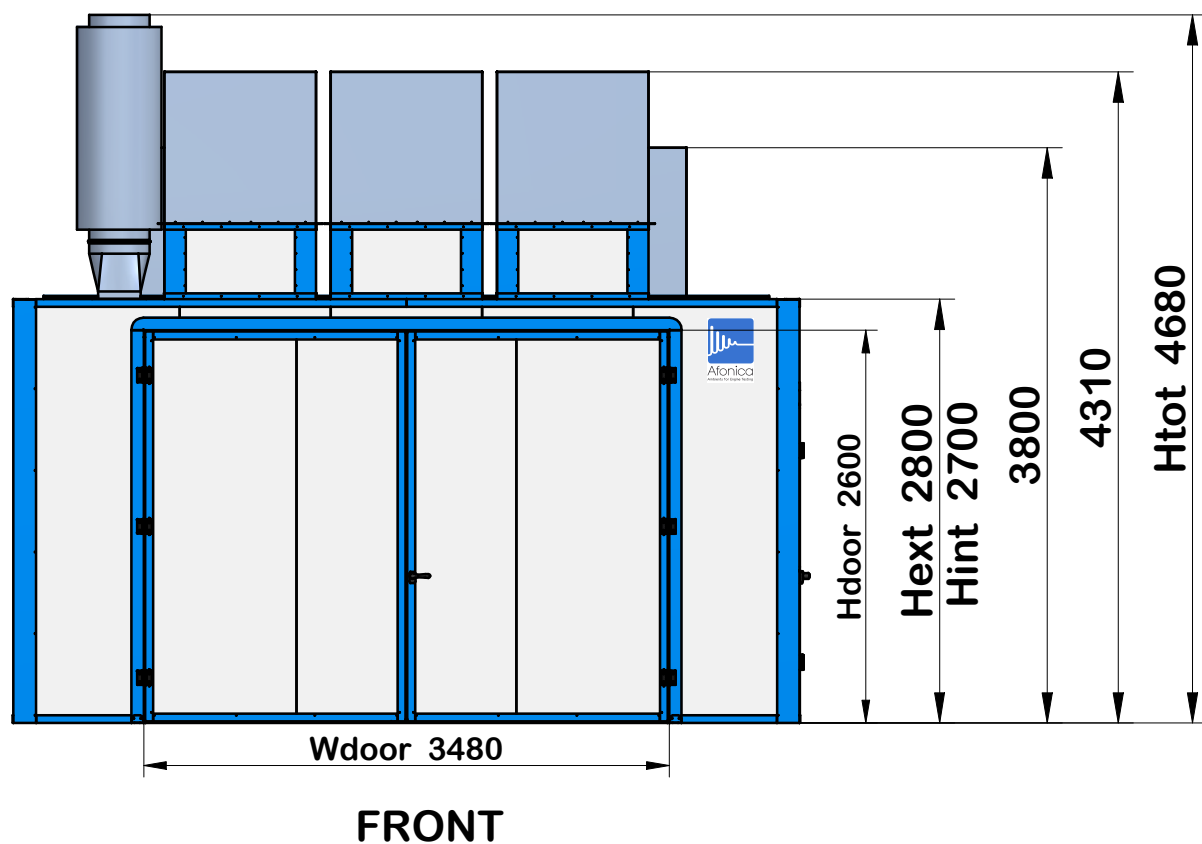

GAMMA AFONICA AST						
CODE	W int (m)	P int (m)	L/M/H int (m)	DOUBLE DOOR (m)	DOOR (m)	WINDOW (optional) (m)
AST-11	5	7.8	2.7 / 3.0 / 3.5	3.5 x 2.6 / 3.5 x 2.9 / 3.5 x 3.4	1 x 2.2	2 x 1 / 1 x 1
AST-12	5	8.3	2.7 / 3.0 / 3.5	3.5 x 2.6 / 3.5 x 2.9 / 3.5 x 3.4	1 x 2.2	2 x 1 / 1 x 1
AST-13	5	8.8	2.7 / 3.0 / 3.5	3.5 x 2.6 / 3.5 x 2.9 / 3.5 x 3.4	1 x 2.2	2 x 1 / 1 x 1
AST-14	5	9.3	2.7 / 3.0 / 3.5	3.5 x 2.6 / 3.5 x 2.9 / 3.5 x 3.4	1 x 2.2	2 x 1 / 1 x 1
AST-15	5	9.8	2.7 / 3.0 / 3.5	3.5 x 2.6 / 3.5 x 2.9 / 3.5 x 3.4	1 x 2.2	2 x 1 / 1 x 1
AST-16	5.5	7.8	2.7 / 3.0 / 3.5	3.5 x 2.6 / 3.5 x 2.9 / 3.5 x 3.4	1 x 2.2	2 x 1 / 1 x 1
AST-17	5.5	8.3	2.7 / 3.0 / 3.5	3.5 x 2.6 / 3.5 x 2.9 / 3.5 x 3.4	1 x 2.2	2 x 1 / 1 x 1
AST-18	5.5	8.8	2.7 / 3.0 / 3.5	3.5 x 2.6 / 3.5 x 2.9 / 3.5 x 3.4	1 x 2.2	2 x 1 / 1 x 1
AST-19	5.5	9.3	2.7 / 3.0 / 3.5	3.5 x 2.6 / 3.5 x 2.9 / 3.5 x 3.4	1 x 2.2	2 x 1 / 1 x 1
AST-20	5.5	9.8	2.7 / 3.0 / 3.5	3.5 x 2.6 / 3.5 x 2.9 / 3.5 x 3.4	1 x 2.2	2 x 1 / 1 x 1
AST-21	6	7.8	2.7 / 3.0 / 3.5	3.5 x 2.6 / 3.5 x 2.9 / 3.5 x 3.4	1 x 2.2	2 x 1 / 1 x 1
AST-22	6	8.3	2.7 / 3.0 / 3.5	3.5 x 2.6 / 3.5 x 2.9 / 3.5 x 3.4	1 x 2.2	2 x 1 / 1 x 1
AST-23	6	8.8	2.7 / 3.0 / 3.5	3.5 x 2.6 / 3.5 x 2.9 / 3.5 x 3.4	1 x 2.2	2 x 1 / 1 x 1
AST-24	6	9.3	2.7 / 3.0 / 3.5	3.5 x 2.6 / 3.5 x 2.9 / 3.5 x 3.4	1 x 2.2	2 x 1 / 1 x 1
AST-25	6	9.8	2.7 / 3.0 / 3.5	3.5 x 2.6 / 3.5 x 2.9 / 3.5 x 3.4	1 x 2.2	2 x 1 / 1 x 1

Legenda:

[W] = Width

[P] = Depth

[L] = Minimum Height (ext 2.8 m)

[M] = Medium Height (ext 3.1 m)

[H] = Maximum Height (ext 3.6 m)

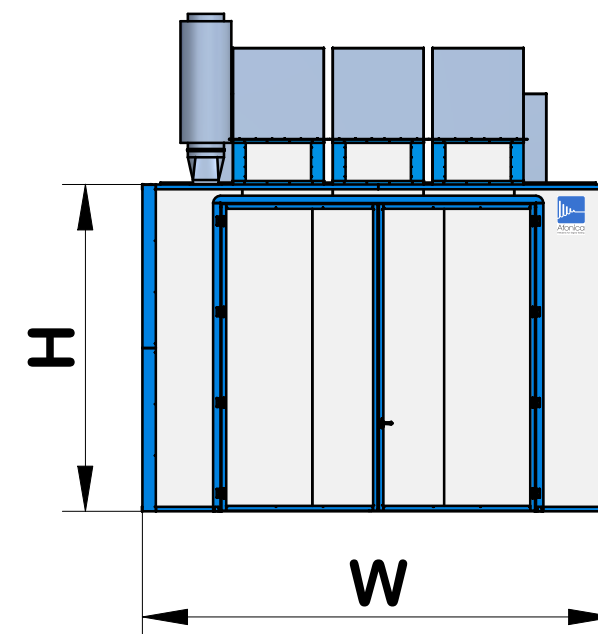
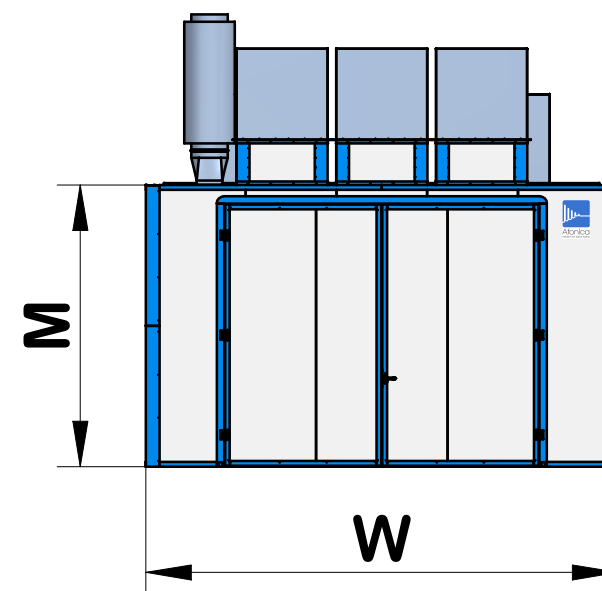
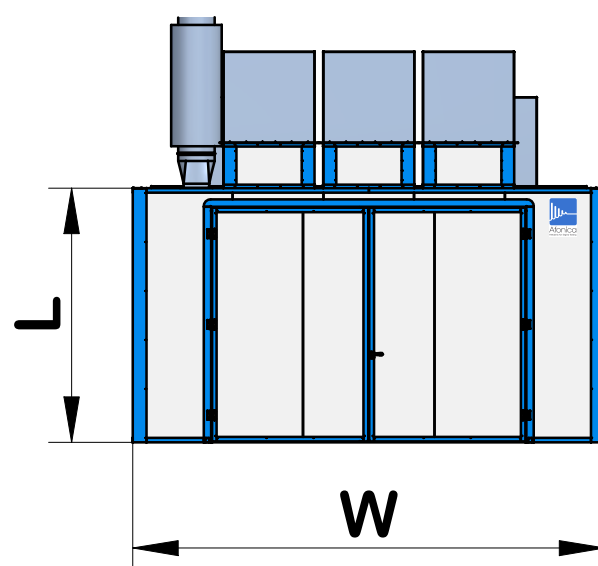
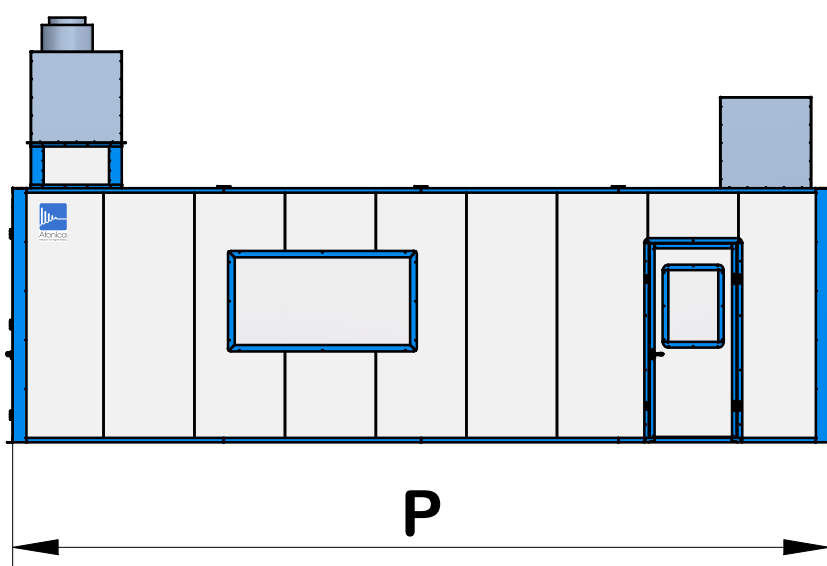

(AST-13-L)

(AST-13-M)

(AST-13-H)

Example Model: AST-13-L

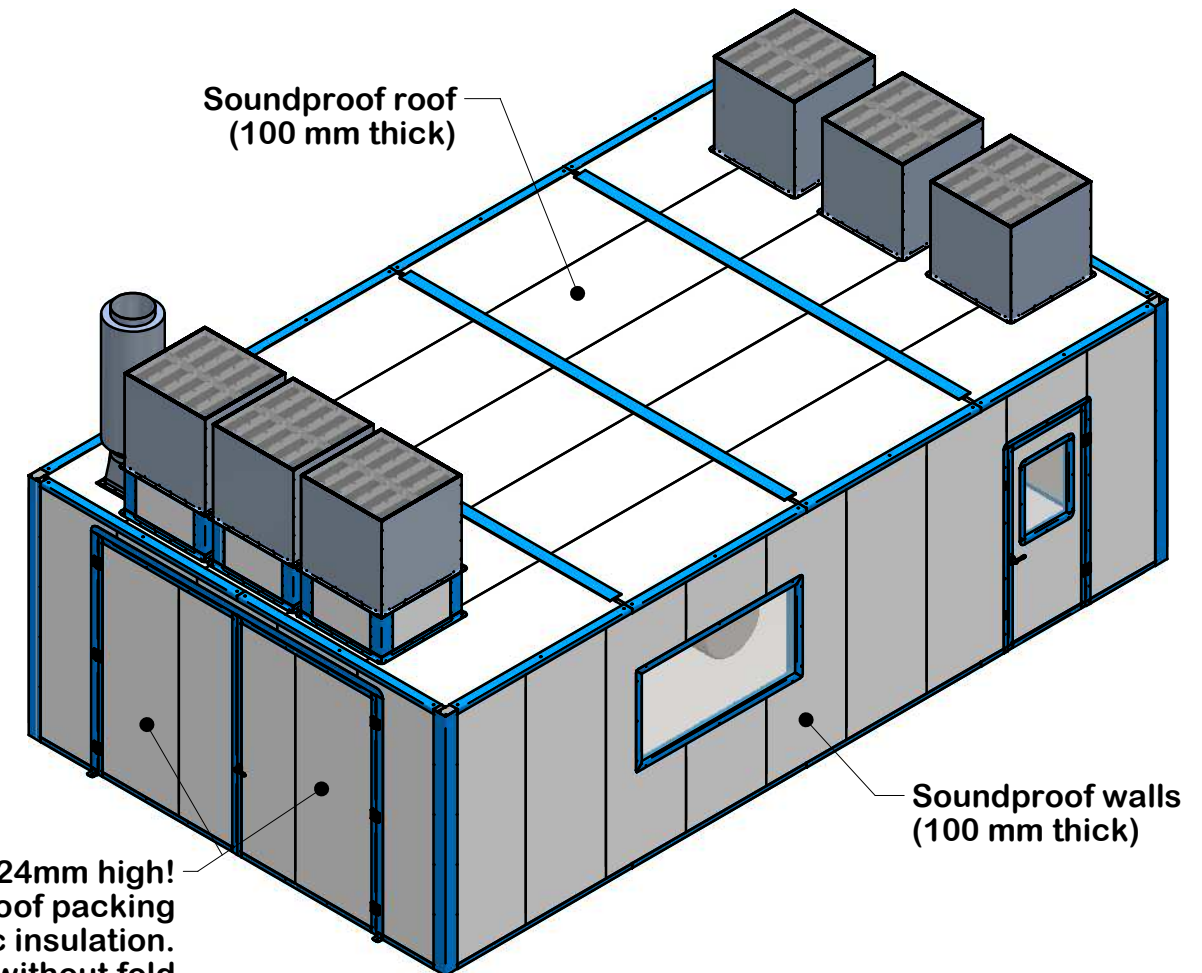
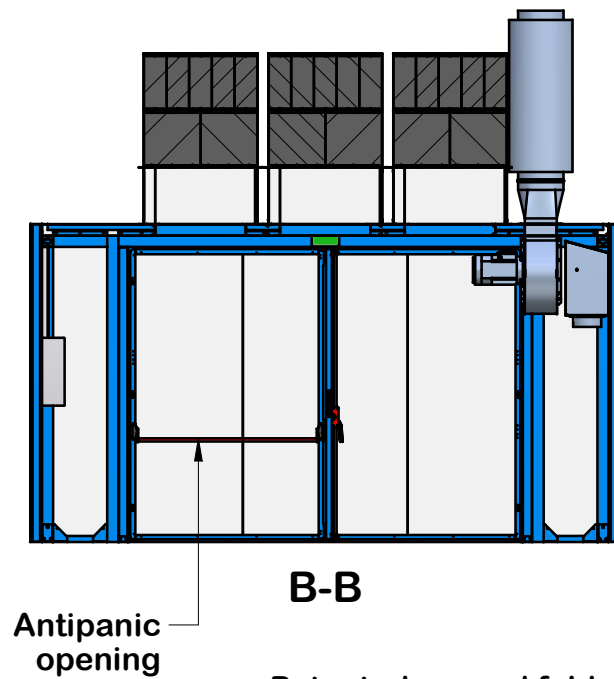
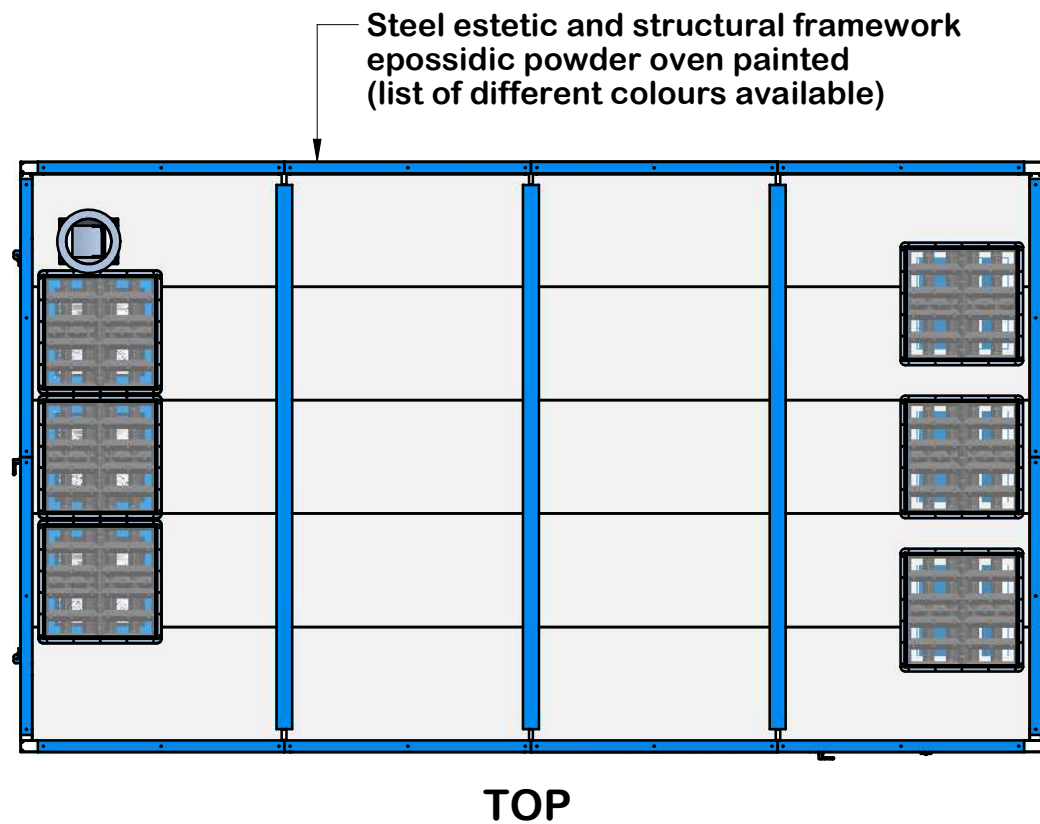
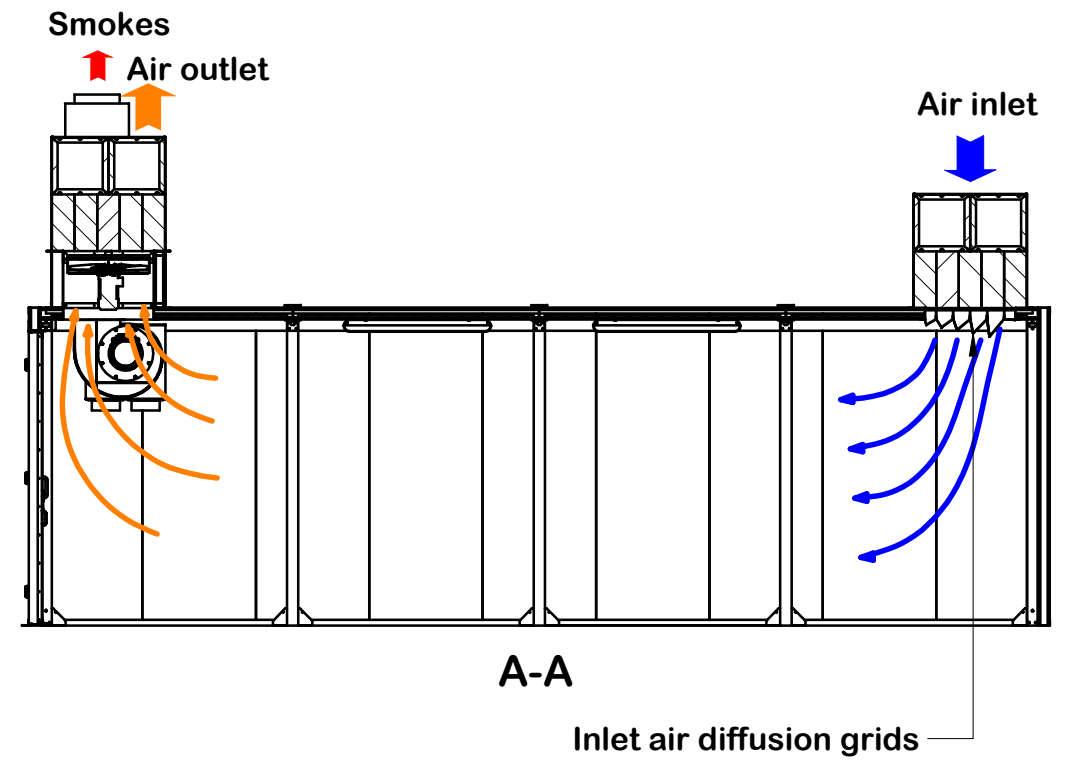
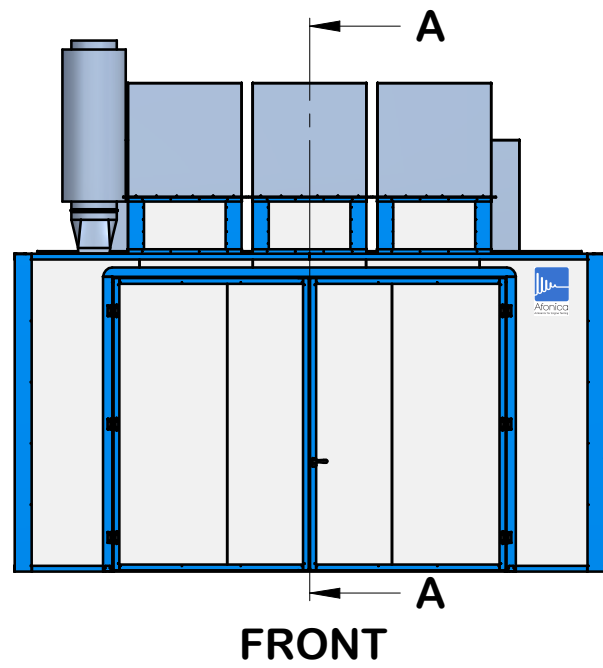
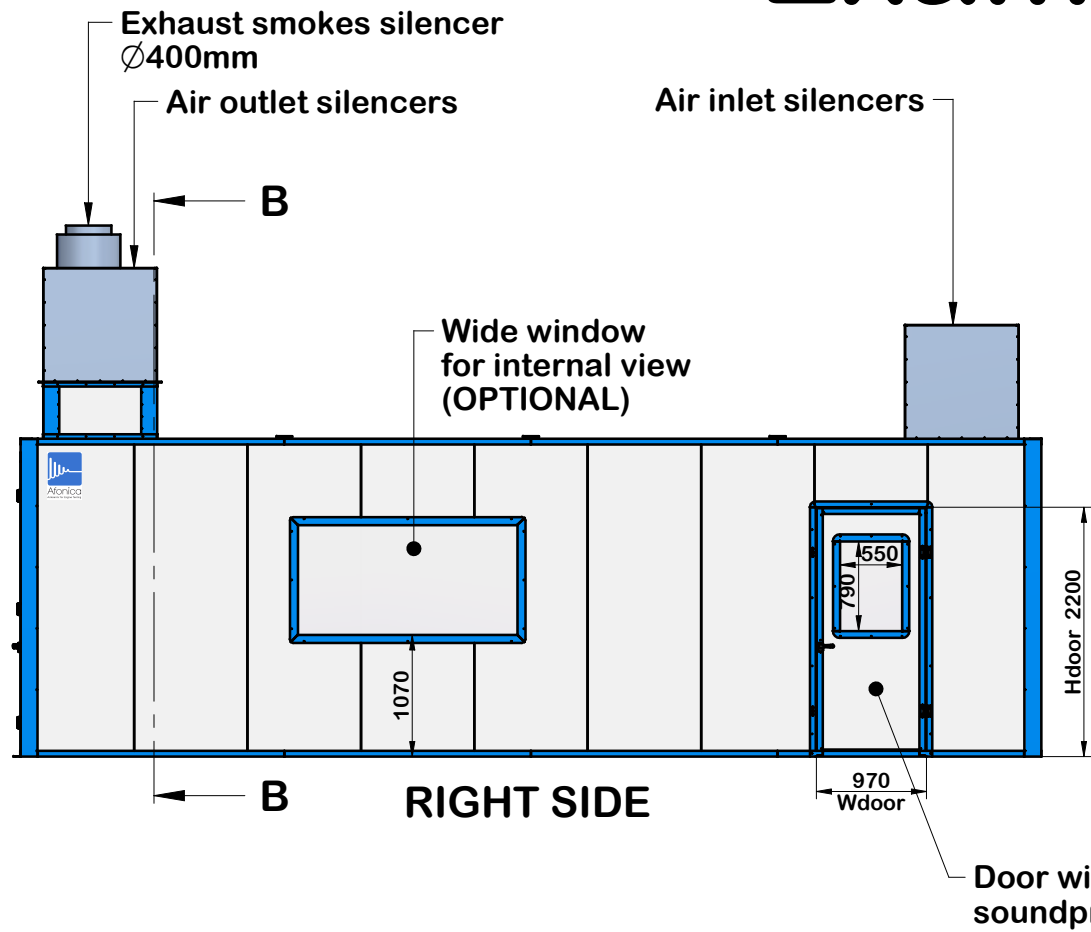

Patented ground fold only 24mm high!
 Complete of proof packing to guaranty a perfect acoustic insulation.
 PS: doors without fold reduce the acoustic insulation of 10 dB and more.

AST-13-L

Accessories: Models of SILENCERS

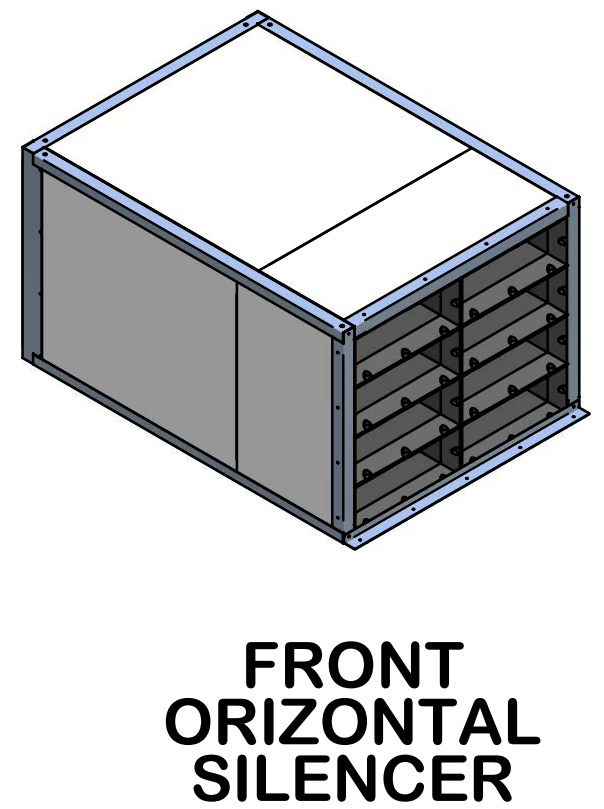
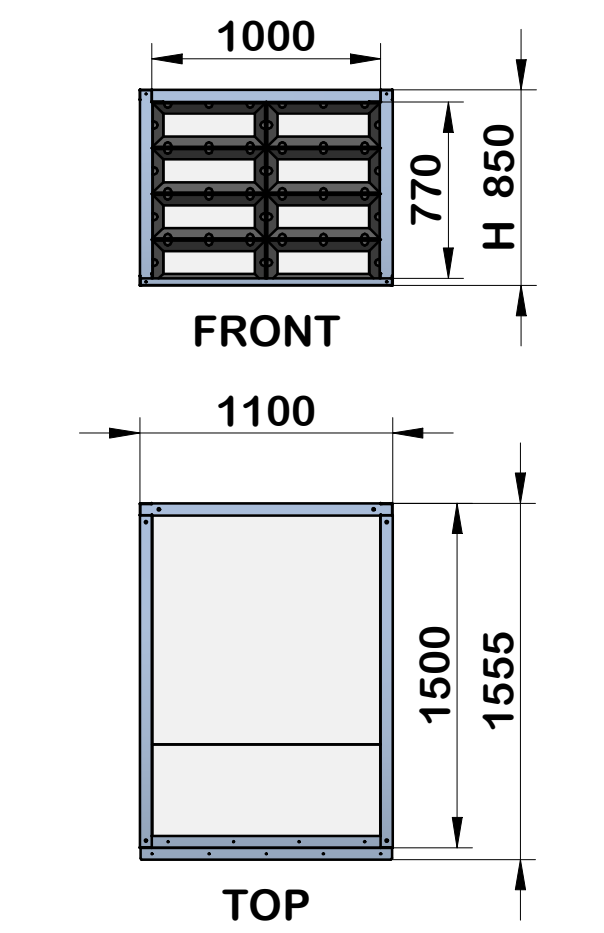
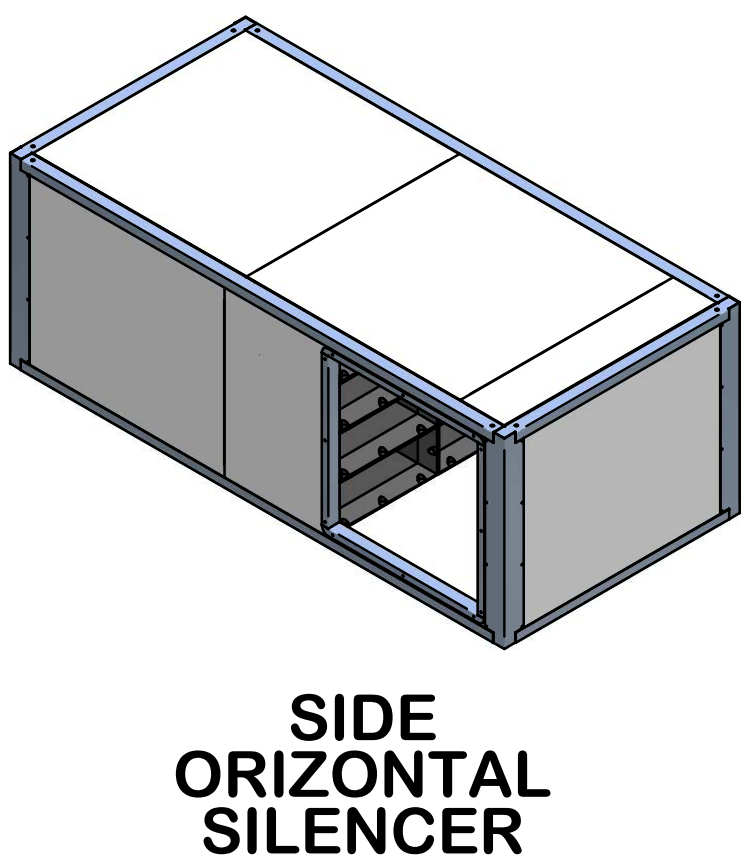
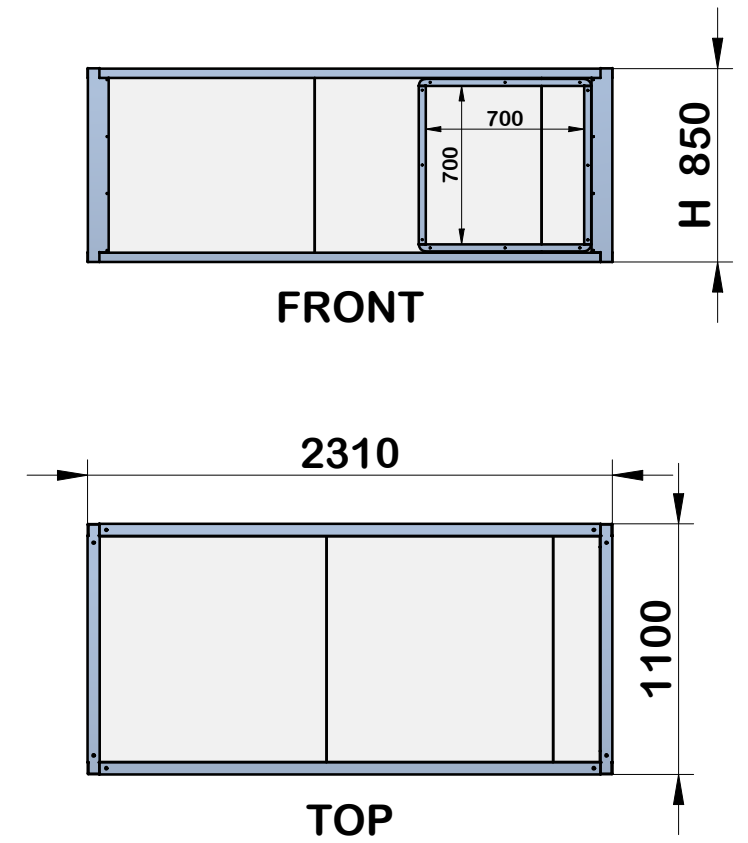
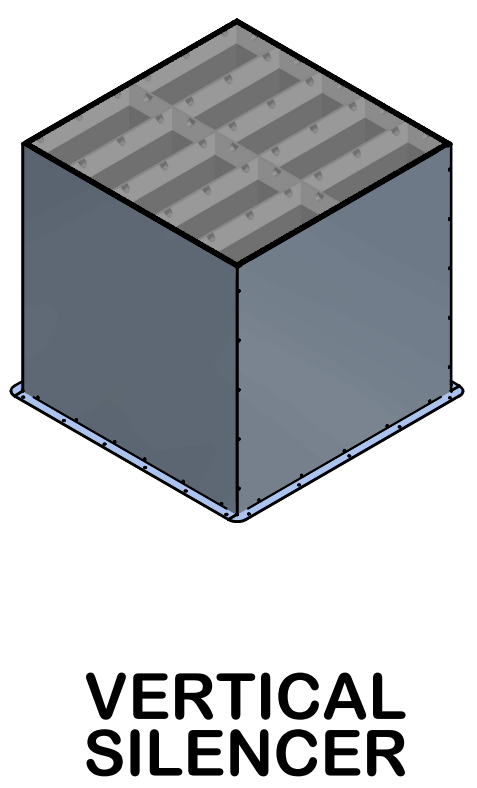
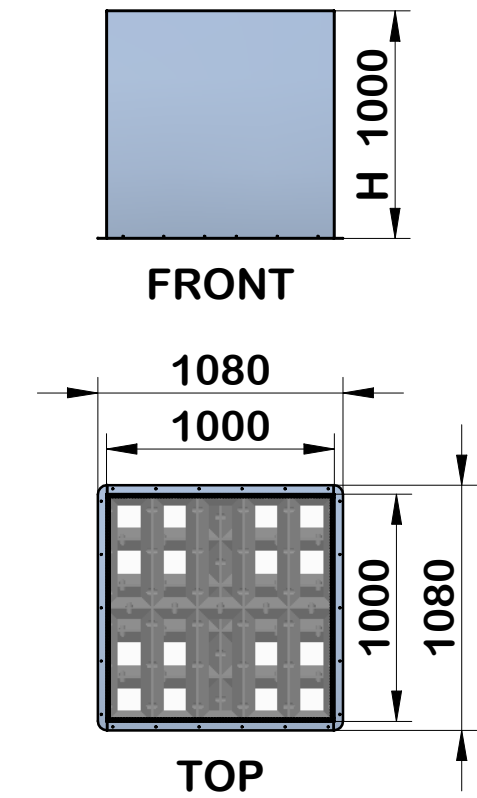

Accessories: SINGLE DOORS

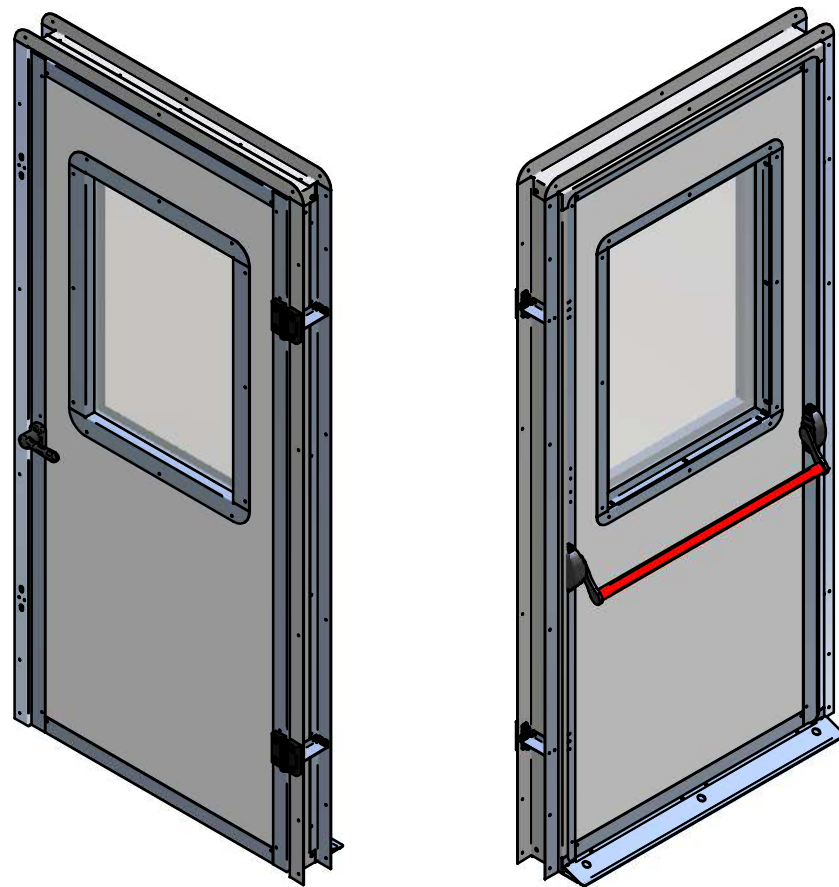
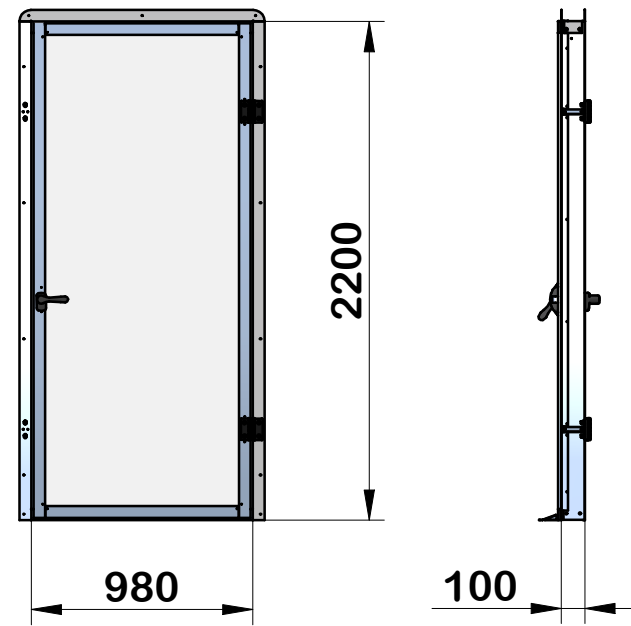
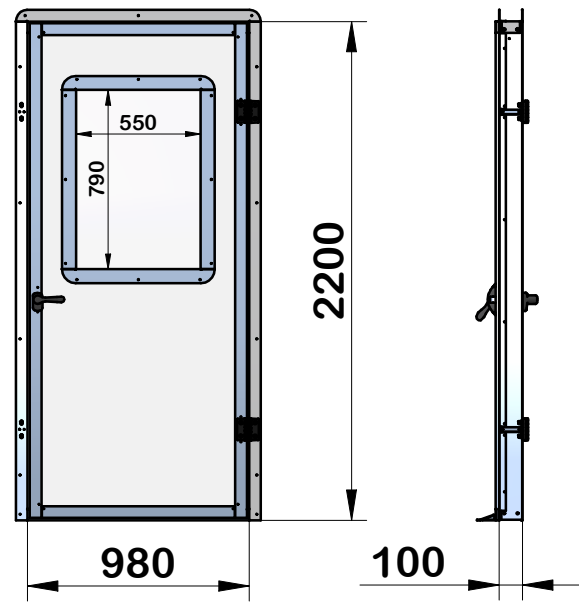

**DOOR
WITH WINDOW**

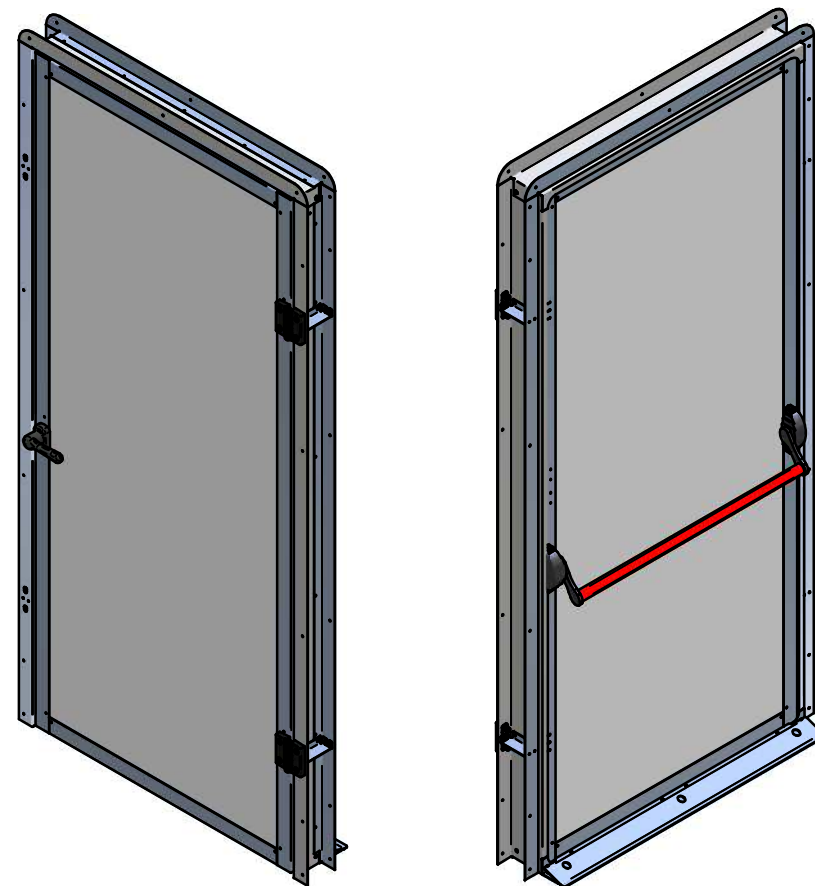

**DOOR
WITHOUT WINDOW**

Accessories: WINDOWS (optional)

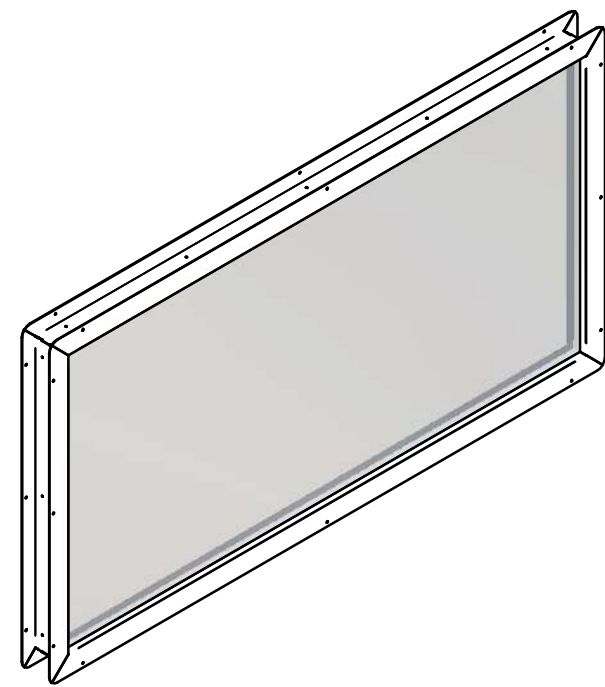
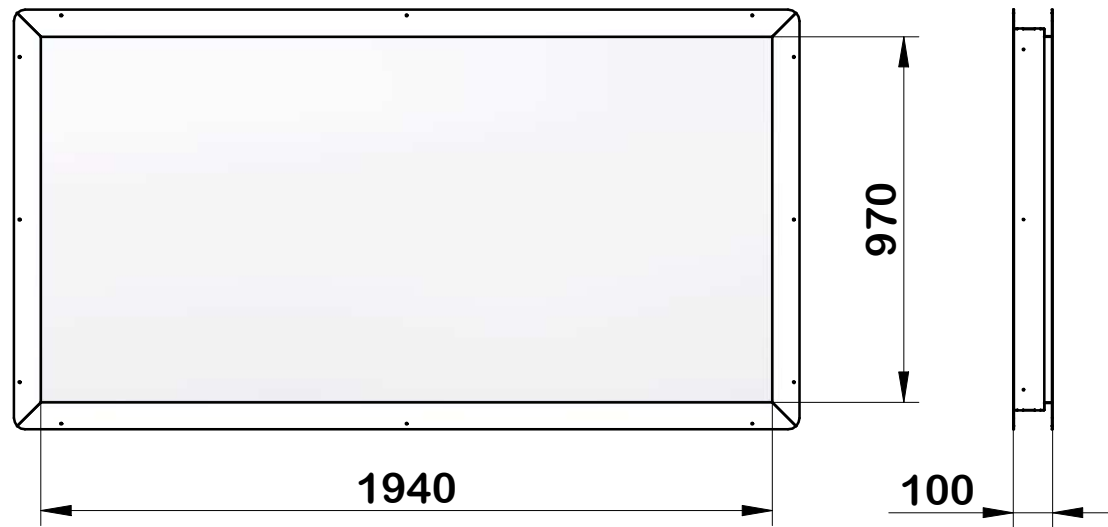

WINDOW
2m x 1m

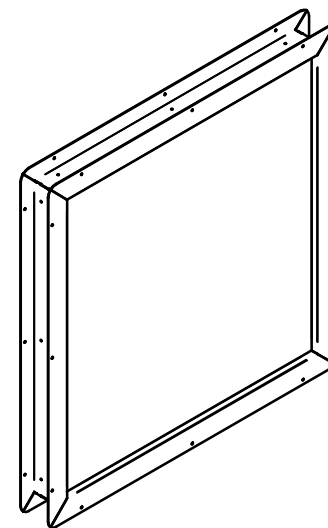
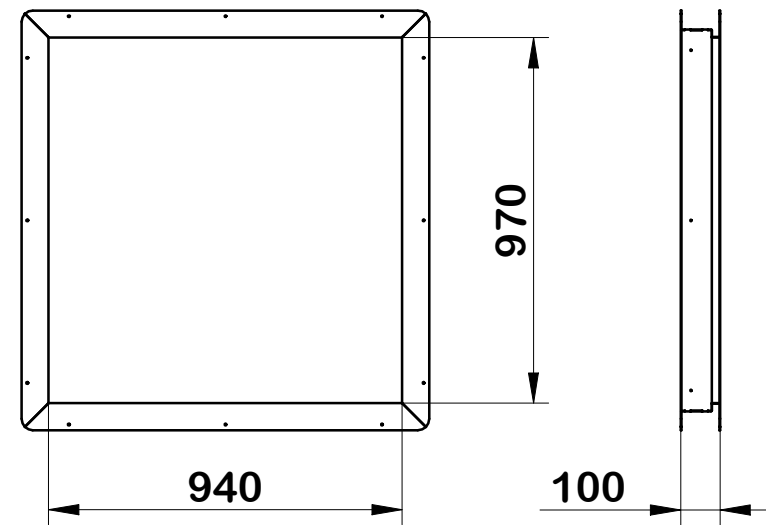

WINDOW
1m x 1m

Accessories*: ELECTRICAL PLANT

(optional)

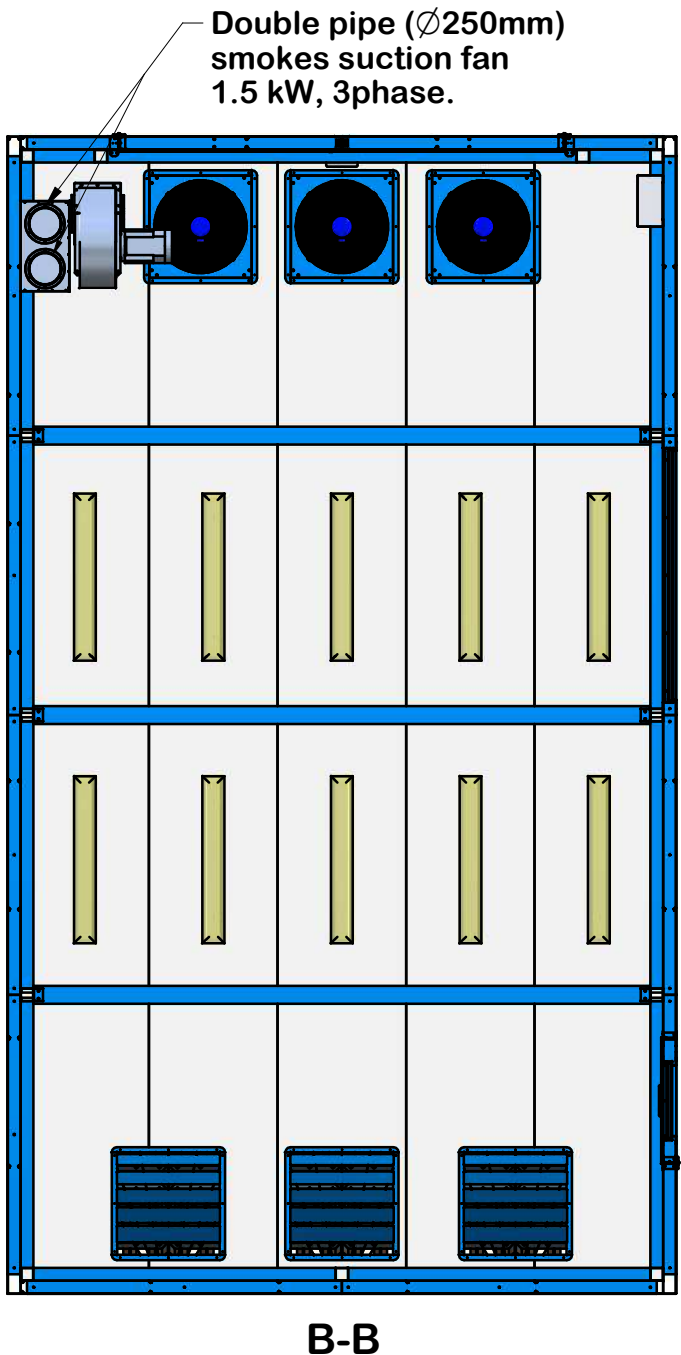
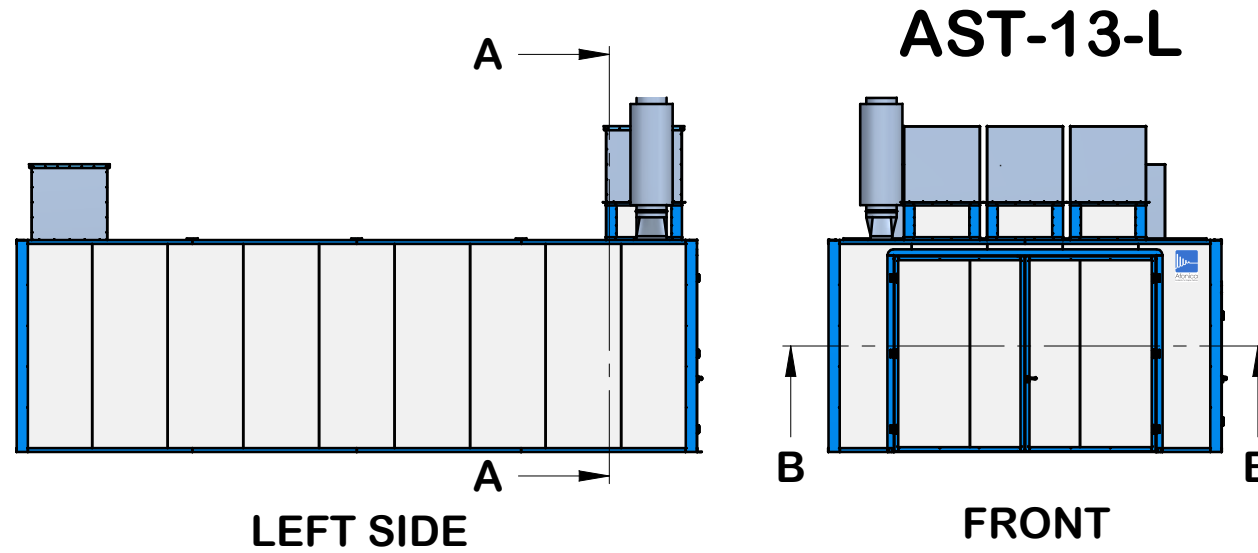
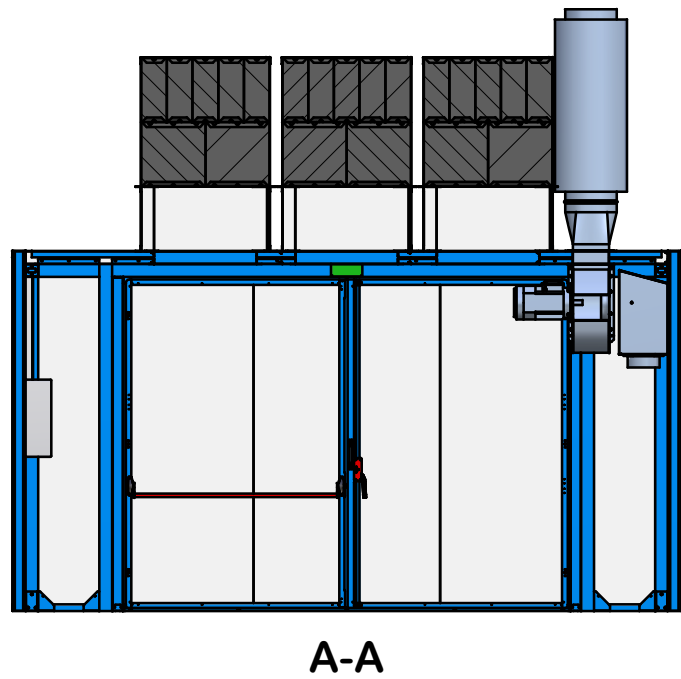

Double pipe (Ø250mm)
smokes suction fan
1.5 kW, 3phase.

Exhaust gas suction fan
1,5 kW 3phase
(or different in relation to
the engines to test).

Waterproof led lights
45 W/cad.

Air extraction fan
4 kW 3phase

Emergency
led light

Kit socket
MF-32A

Electrical control panel
with switch on/off
and socket monophase 3P 16A

* Available in version 4.0